

# Couplings for Tubes

## Nut and Sleeve Integrated Type

**Straight**

**MCPTK**

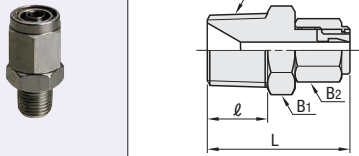

**RoHS10**

Material: SUS316

Part Number Type	Applicable Tube O.D. (mm)	T R (PT) Selection	T R(PT)	Applicable Tube I.D. (mm)	L	l	B <sub>1</sub> (Wrench Flats)	B <sub>2</sub> (Wrench Flats)	Unit Price 1-4 pcs/	Volume Discount Rate 5-20
MCPTK	3.2	1	1/8	1.6	24	9	10	10		
		1	1/8		24	9	10			
	4	2	1/4	2	26	11	14	10		
		1	1/8		26	9	12			
	6	2	1/4	4	28.5	11	14	12		
			3/8		30	12	17			
			1		1/8	28	9		14	
	8	2	1/4	6	30	11	14	14		
			3/8		31	12	17			
			1		1/8	32	11		17	
	10	3	3/8	8	33	12	17	17		
			1/2		36	15	22			
2			1/4		34	11	17			
3			3/8		35	12	17			
12	4	1/2	10	38	15	22	19			

**Elbows**

**MCLPTK**

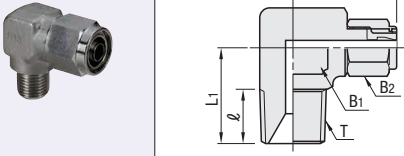

**RoHS10**

Material: SUS316

Part Number Type	Applicable Tube O.D. (mm)	T R (PT) Selection	T R(PT)	Applicable Tube I.D. (mm)	L <sub>1</sub>	L <sub>2</sub>	l	B <sub>1</sub> (Wrench Flats)	B <sub>2</sub> (Wrench Flats)	Unit Price 1-4 pcs/	Volume Discount Rate 5-20
MCLPTK	3.2	1	1/8	1.6	18	20	9	12	10		
		1	1/8		18	20	9	12	10		
	4	2	1/4	2	21	21	11	14	10		
		1	1/8		18	21.5	9	12			
	6	2	1/4	4	21	22.5	11	14	12		
			3/8		23	23.5	12	17			
			1		1/8	19	24	9		14	
	8	2	1/4	6	19	24	11	14	14		
			3/8		23	25	12	17			
			1		1/8	22	26.5	11		17	
	10	3	3/8	8	23	26.5	12	17	17		
			1/2		29	28.5	15	22			
2			1/4		23	27.5	11	17			
3			3/8		27	30	12	22			
12	4	1/2	10	30	30	15	22	19			

**Panel Mount**

**MCBU**

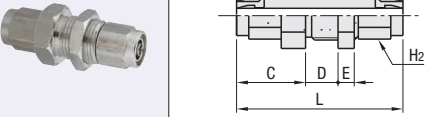

**RoHS10**

Material: SUS316

Part Number Type	No.	Applicable Tube O.D. (mm)	Applicable Tube I.D. (mm)	L	B	Wrench Flats H <sub>1</sub> H <sub>2</sub> H <sub>3</sub>	C	D	E	M	Unit Price 1-4 pcs/	Volume Discount Rate 5-20
MCBU	4	4	2.5	41	6	14	10	14	17	8	4	M12x1.0
	6	6	4	44	7	17	12	17	18.5	8	4	M14x1.0
	8	8	6	47	7.5	19	14	19	20	8	4	M16x1.0
	10	10	8	50	8	22	17	22	21.5	8	4	M18x1.0
	12	12	10	54	9.5	24	19	24	23	8	5	M20x1.0

**Tees**

**MCTPT**

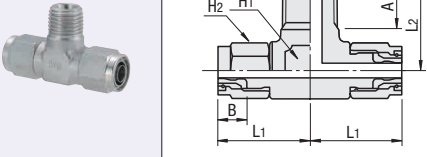

**RoHS10**

Material: SUS316

Part Number Type	No.	Thread Size R (PT)	Applicable Tube O.D. (mm)	Applicable Tube I.D. (mm)	L <sub>1</sub>	L <sub>2</sub>	A	B	Wrench Flats H <sub>1</sub> H <sub>2</sub>	Unit Price 1-9 pcs/	Volume Discount Rate 10-20
MCTPT	4-1	1/8	4	2.5	20	18	9	6	12	10	
	4-2	1/4			21	21	11	6	14	10	
	6-1	1/8	6	4	21.5	18	9	7	12	12	
	6-2	1/4			22.5	21	11	7	14	12	
	8-15	1/8	8	5	23.5	19	9	7.5	14	14	
	8-1	1/8			6	23.5	19	9	7.5	14	14
	8-2	1/4			6	23.5	21	11	7.5	14	14
	8-3	3/8	10	6	25	23	12	7.5	17	14	
	8-36	3/8			6	25	23	12	7.5	17	14
	10-2	1/4			8	28.5	25	11	8	22	17
	10-36	3/8	12	8	6.5	28.5	26	12	8	22	17
	10-3	3/8			8	28.5	26	12	8	22	17
	12-28	1/4			8	30	26	11	9.5	22	19
	12-2	1/4	12	10	10	30	26	11	9.5	22	19
	12-3	3/8			10	30	27	12	9.5	22	19

**Unions**

**MCUN**

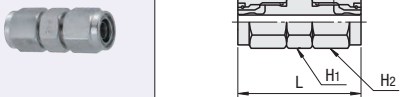

**RoHS10**

Material: SUS316

Part Number Type	No.	Applicable Tube O.D. (mm)	Applicable Tube I.D. (mm)	L	B	Wrench Flats H <sub>1</sub> H <sub>2</sub>	Unit Price 1-9 pcs/	Volume Discount Rate 10-20
MCUN	4	4	2.5	28	6	10	10	
	6	6	4	32	7	12	12	
	8	8	6	36	7.5	14	14	
	10-6	10	6.5	40	8	17	17	
	10	10	8	40	8	17	17	
	12-8	12	8	44	9.5	17	19	
	12-9	12	9	44	9.5	17	19	
	12	12	10	44	9.5	17	19	

**Union Tees**

**MCUT**

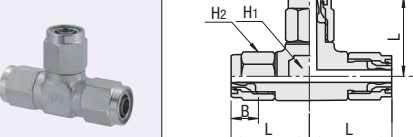

**RoHS10**

Material: SUS316

Part Number Type	No.	Applicable Tube O.D. (mm)	Applicable Tube I.D. (mm)	L	B	Wrench Flats H <sub>1</sub> H <sub>2</sub>	Unit Price 1-9 pcs/	Volume Discount Rate 10-20
MCUT	4	4	2.5	20	6	12	10	
	6	6	4	21.5	7	12	12	
	8-5	8	5	23.5	7.5	14	14	
	8	8	6	23.5	7.5	14	14	
	10	10	8	28.5	8	22	17	
	12-8	12	8	30	9.5	22	19	
	12-9	12	9	30	9.5	22	19	
	12	12	10	30	9.5	22	19	

Ordering Example: Part Number - T  
MCPTK4 - 1