

■ **Features:** Hole positions are offset. Can be combined with plates of 3mm thickness when using taps for mounting covers.

■ **Eccentric Brackets**

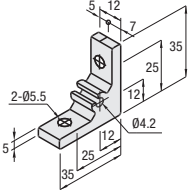

**HBLTH5**  
**HBLTHB5**  
(Black Anodize)



Type	M Material	S Surface Treatment
HBLTH5	A6N01SS-T5	Anodize
HBLTHB5		Black Anodize

Part Number	Mass (g)	Applicable Screw, T Nut				Allowable Load (N)	Unit Price (1-99 pcs)	Volume Discount Rate (100-200)
		Screw	Quantity	T Nut	Quantity			
HBLTH5	15	CBM5-10	2	HNNT5-5	2	833		
HBLTHB5* (Black Anodize)								

\* For repairing black anodizing, refer to P.846.



Example  
HBLTH5 and HBLTHB5 are offset. Can be combined with both cover plates of 5mm and 3mm thickness.

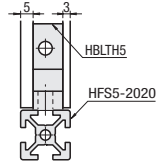

■ **Features:** Tabbed Reversal Brackets with two mounting holes on one side can connect extrusions more securely.

■ **Thick Brackets**



**HBLTSW5**

**HBLTVW5**

Part Number	Mass (g)	Applicable Screw, T Nut				Allowable Load (N)	Unit Price (1-99 pcs)	Volume Discount Rate (100-200)
		Screw	Quantity	T Nut	Quantity			
HBLTSW5	26	CBM5-10	4	HNNT5-5	4	1176		
HBLTVW5	36							

■ **Features:** Extruded Brackets with Unequal Sides. Effective when strength is required in narrow clearances between extrusions.

■ **Scalene Brackets**



**HBLTF5**

Part Number	Mass (g)	Applicable Screw, T Nut				Allowable Load (N)	Unit Price (1-99 pcs)	Volume Discount Rate (100-200)
		Screw	Quantity	T Nut	Quantity			
HBLTF5	21	CBM5-10	3	HNNT5-5	3	1004		

Ordering Example  
Part Number: HBLTSW5

Alterations Part Number: HBLTF5 (C, SET, SST, SEU, SSU, SEP, SSP, SEC) SET

Alterations	Code	Spec.	Applicable Bracket
Mounting Hole Alteration for Cover	C	Adds taps on a bracket for cover mounting. (M5 on Both Sides) (Mounting Screw HCBM on P.754)	NBLTS5
			HBLTS5
			HBLTS5-4
			CHBLTS5
			HBLTV5
			HBLTVB5
			NBLUS5
			HBLUS5
			HBKTS5
			HBKUS5
			HBLUS5
			HBLTH5
HBLTHB5			
HBLTSW5			
HBLTVW5			
HBLTF5			

Alterations	Code	Spec.	Applicable Bracket
Applicable Screws and Nuts Set	SET SST (Stainless Steel) SEU Pre-Assembly Insertion Spring Nuts SSU Pre-Assembly Insertion Spring Nuts (Stainless Steel) SEP Post-Assembly Insertion Spring Nuts (Stainless Steel) SSP Post-Assembly Insertion Spring Nuts SEC Screws with Captured Washer and Nuts	Applicable screws and nuts for fixing the brackets on extrusions come in a set. (Adds to the bracket price)  (Ex.) When HBLTS5 is specified:  Code Screw Nut SET CBM5-10 HNNT5-5 SST SCB5-10 HNNTB5-5 SEU CBM5-10 HNTU5-5 SSU SCB5-10 SHNTU5-5 SEP CBM5-10 HNTP5-5 SSP SCB5-10 SHNTP5-5 SEC HCBST5-12 HNNT5-5  *When specifying other than HBLTS5, check for the applicable screws and nuts.	NBLTS5
			HBLTS5
			HBLTS5-4
			HBLTSB5
			CHBLTS5
			HBLTV5
			HBLTVB5
			HBKTS5
			HBKUS5
			HBLUS5
			HBKUS5
			HBLTH5
HBLTHB5			
HBLTSW5			
HBLTVW5			
HBLTF5			

\* Screws for black anodized brackets are HCBMTB (Trivalent Chromate Black) on P.751.  
 \* Included Screw is not RoHS compliant when -SET, -SEU or -SEP other than black anodized brackets is specified.