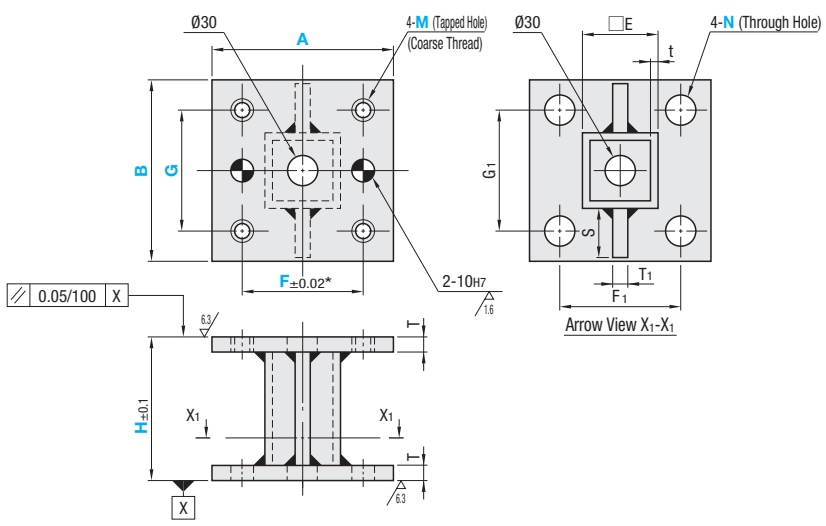

Welded Steel Stands

Shaped Steel, Height Configurable

■ **Features:** When the mounting hole pitch does not match with the fixed height / dimension on the left-hand page, the following standard is available.

Type	Material	Surface Treatment
YSCFT	SS400	-
YSSFT		Black Oxide
YSMFT		Electroless Nickel Plating

RoHS10

⚠ Tolerance is applicable to Dh7.

Part Number		B	1mm Increment			Selection		T	T ₁	E	t	S	F ₁	G ₁		
Type	A		H	G	F	M (Tapped Hole)	N (Through Hole)									
YSCFT YSSFT YSMFT	100	100	100~300	30~80	70~80	8 10 12	9 11 14	10	9	50	3.2	22	80	80		
		120		30~100								32		100		
		150		30~130								44		130		
	125	120		30~100	95~100					14	12	75	4.5	19	100	100
	150	150		30~120	95~120									32	120	120
	200	200		30~170	120~170									44	160	160

Ordering Example: Part Number - B - H - G - F - M - N
 YSCFT100 - B150 - H251 - G80 - F74 - M8 - N11

Alterations: Part Number - B - H - G - F - M - N - (HKC)
 YSCFT100 - B150 - H251 - G80 - F74 - M8 - N11 - HKC

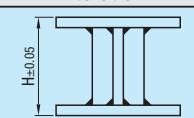
Alteration	Code	Spec.
	HKC	Changes the tolerance of dimension H to H±0.05. Ordering Code: HKC

A	B	H 1mm Increment	Unit Price				
			YSCFT	YSSFT	YSMFT		
100	100	100~150					
		151~200					
		201~250					
	120	100~150	100~150				
			151~200				
			201~250				
		150	100~150	100~150			
				151~200			
				201~250			
	125	120	100~150				
			151~200				
			201~250				
150		100~150	100~150				
			151~200				
			201~250				
200	200	100~150					
		151~200					
		201~250					
	251~300	100~150	100~150				
			151~200				
			201~250				