

Welded Steel Stands

Shaped Steel

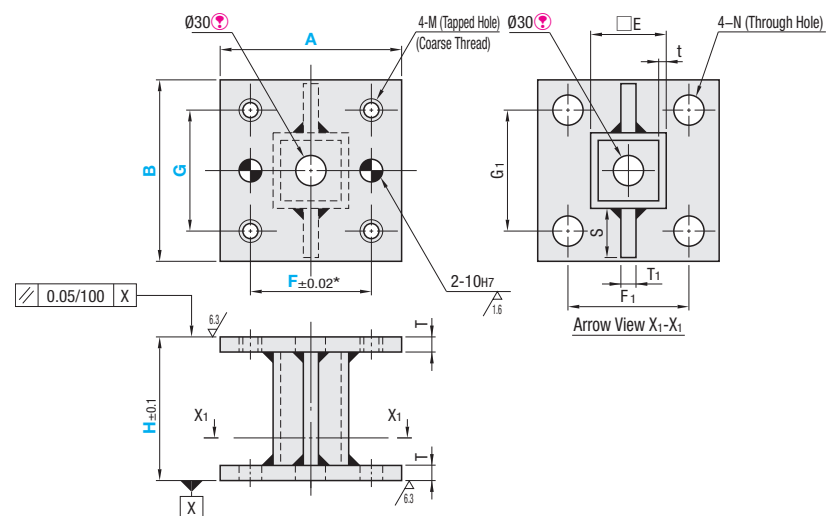

Type		M	S
No Hole	Hole Position Configurable	Material	Surface Treatment
YSSTC	YSST	SS400	-
YSSTB	YSST		Black Oxide
YSSTM	YSMT		Electroless Nickel Plating
-	YSFT	SUS304	-



RoHS 10

⌀30 hole is common to No Hole Type and Hole Position Configurable Type. Ⓢ Tolerance is applicable to D_{H7} dowel holes.

No Hole

Part Number		B	H Selection	T	T ₁	E	t	S	Unit Price								
									YSSTC			YSSTB			YSSTM		
Type	A								H100	H150 H200	H250 H300	H100	H150 H200	H250 H300	H100	H150 H200	H250 H300
YSSTC YSSTB YSSTM	100	100	100	10	9	50	3.2	22									
		120	150					32									
		150	200					44									
	125	120	200	14	12	75	4.5	19									
			250					32									
			300					44									
150	150	300			100												
200	200																

Hole Position Configurable

Part Number		B	H Selection	1mm Increment		T	T ₁	E	t	S	F ₁	G ₁	M	N	Unit Price											
				G	F										YSCT			YSST			YSMT			YSFT		
Type	A														H100	H150 H200	H250 H300	H100	H150 H200	H250 H300	H100	H150 H200	H250 H300			
YSCT YSST YSMT YSFT	100	100	100	30-80	70-80	10	9	50	3.2	22	80	100	M10	11												
		120	150	30-100	30-130										44	80	100									
		150	200	30-100	95-100										44	100	100									
	125	120	250	14	12	75	4.5	32	120	120	120	160	M12	14												
			300												35-120	95-120	44	120	120							
			200												35-170	120-170	44	160	160							



Ordering Example

Part Number - B - H - G - F
 YSSTB100 - B150 - H300
 YSST150 - B150 - H200 - G100 - F95



Alterations

Part Number - B - H - G - F - (HK)
 YSST150 - B150 - H200 - G100 - F95 - HKC

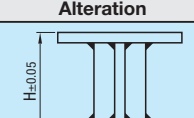
Alteration	Code	Spec.
	HKC	Changes the tolerance of dimension H to H±0.05. Ordering Code HKC