

# [High Precision] X-Axis Dovetail Slide, Rack & Pinion

## Rectangular, Compact Carriage

■ **Features:** Dovetail slide stages with 18mm travel per knob rotation. Rectangular form factor contributes to space saving designs. (XFG on P.1911)

### ■ X-Axis, Rectangular



XY-Axis P.1939  
Z-Axis P.1954



#### XWG40

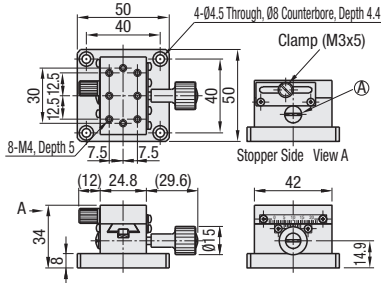

#### XWG60

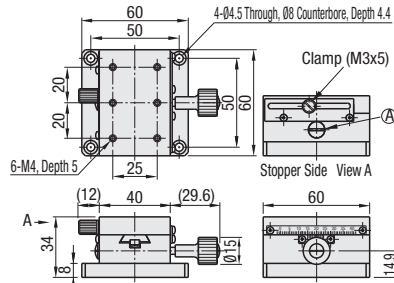

#### XWG90

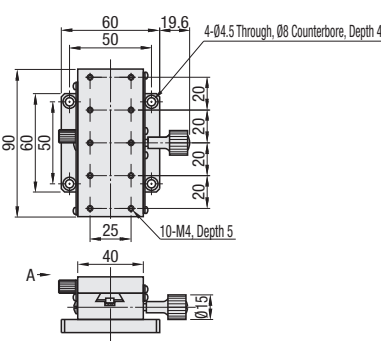

#### XWG140

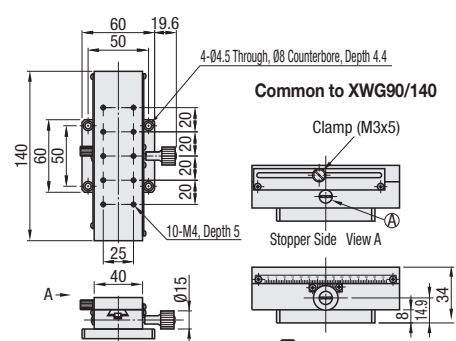

Common to XWG90/140

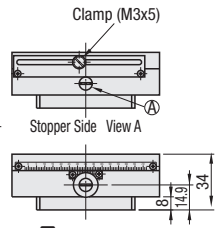

\* By turning the preload adjustment screw (A) clockwise with a flathead screwdriver, the stage slides slowly, and by turning counterclockwise the stage slides quickly and smoothly.

M Material: Aluminum Alloy  
S Surface Treatment: Black Anodize

◊ Standard Stages Similar Products: XDTS (P. 1903) ◊ Long Stroke: XLWG (P. 1908), XLONG (P. 1909), XLARGE (P. 1910)

Part Number	No.	Stage Surface (mm)	Travel Distance (mm)	Travel per Rotation (mm)	Load Capacity (N)		Travel Accuracy Straightness	Weight (kg)	Unit Price
					Horizontal	Vertical			
XWG	40	24.8x42	±12	18	29.4	14.7	30µm	0.17	
	60	40x60	±21		39.2	19.6		0.29	
	90	40x90	±35					0.40	
	140	40x140	±60					0.56	

◊ Resolution (Vernier Scale Indication): 0.1mm/division

◊ Knob Cover HDCVR15 (Sold Separately): Ø15 knobs can be increased in diameter by installing the cover. P.2004

Ordering Example Part Number XWG40

■ **Features:** Compact Dovetail Slide Rack and Pinion Stages (width: 24.8mm) with 18mm travel per knob rotation.

### ■ X-Axis, Compact Carriage

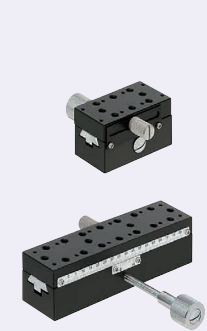

#### XSP

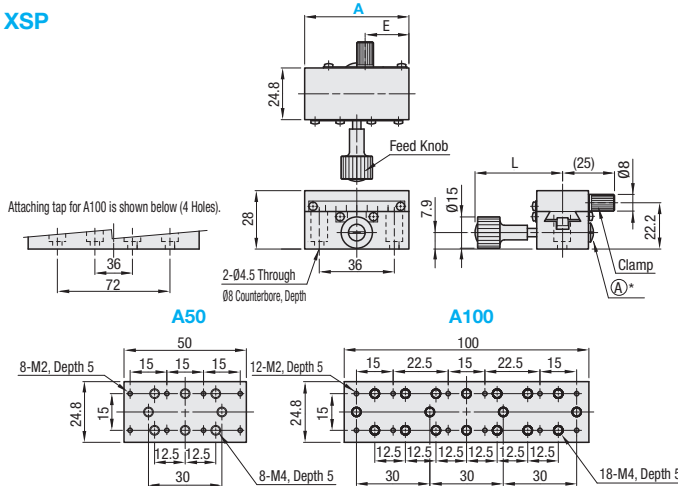

\* By turning the preload adjustment screw (A) clockwise with a flathead screwdriver, the stage slides slowly, and by turning counterclockwise the stage slides quickly and smoothly.

M Material: Aluminum Alloy  
S Surface Treatment: Black Anodize

Part Number	Type	Stage Surface (mm)	Travel Distance (mm)	Travel per Rotation (mm)	L	E	Load Capacity (N)		Travel Accuracy Straightness	Weight (kg)	Accessory (2 pcs.) Type M-L	Unit Price
							Horizontal	Vertical				
XSP	A	50x24.8	±16	18	42	21	29.4	14.7	30µm	0.13	SCB4-8	
	100	100x24.8	±40		63	46	39.2	19.6				0.24

◊ Resolution (Vernier Scale Indication): 0.1mm/division

◊ Knob Cover HDCVR15 (Sold Separately): Ø15 knobs can be increased in diameter by installing the cover. P.2004

◊ Adjustable Plate XPLT: Use this plate when connecting stages with non-matching mounting holes. P.1915

Ordering Example Part Number XSP100