

FOR PLASTIC HEAVY DUTY FLEX CHAIN

CURVE



MODU-SPROCKET

Material : Mono Cast Nylon

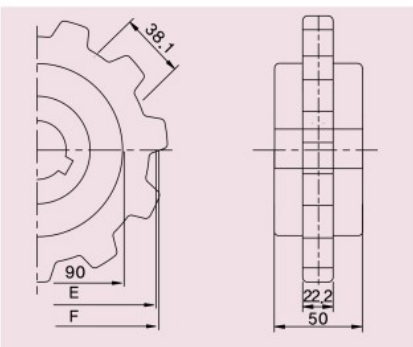

TEETH	BORE	CODE.NO	PITCH	OUTSIDE	WEIGHT
	MM		DIAMETER(E)	DIAMETER(F)	
10	25	1581	123.3	122	0.48
	30	1582			
	35	1583			
11	25	1584	135.2	134	0.53
	30	1585			
	35	1586			
12	25	1587	147.2	146	0.60
	30	1588			
	35	1589			



COMBI-IDLER

Material : Polyethylene

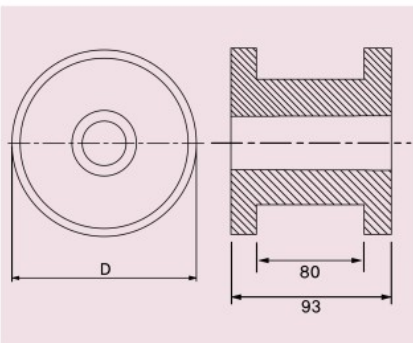

FOR TEETH	BORE	CODE.NO	OUTSIDE	WEIGHT
	MM		DIAMETER(D)	
10	25	1741	122	0.72
	30	1742		
	35	1743		
11	25	1744	134	0.78
	30	1745		
	35	1746		
12	25	1747	146	0.92
	30	1748		
	35	1749		