

◆ Characteristic / 特點 :

- Build-in twin LED, convenient for checking the operation.
/ 具有雙LED，檢測操作更方便。
- Plug-in connector type is available, easy to connect, anyone can replace the new sensor in a minute.
/ 插入式接線，安裝更換很容易。



◆ Specifications / 規格表 :

Output method / 輸出模式	NPN N.O.	RN05-N	RN05-ND1
	PNP N.O.	RN05-P	RN05-PD1
	NPN N.O./N.C. PNP N.O./N.C.	RN05-NP	-
Sensing distance / 檢出距離	5mm		
Secure sensing distance / 建議距離	0 to 4mm		
Standard sensing object / 標準檢測物	Iron 18x18x1mm		
Sensing Surface / 檢測方向	Top surface / 前方		
Hysteresis / 遲滯	≤ 10% of sensing distance		
Response time / 反應時間	2ms Max		
Operating voltage / 工作電壓	DC 10 ~ 30V		
Current consumption / 消耗電流	≤ 8 mA no-load		
Load current / 負載電流	100 mA Max at DC 30V		
Leakage current / 漏電流	≤ 1.1 mA no-load		
Residual voltage / 殘餘電壓	≤ DC 1.5V		
Insulation resistance / 隔離阻抗	20M Ω min. (DC500V)		
Voltage withstandability / 絕緣耐壓	AC1000V 60Hz for 60 Sec.		
Operating temperature / 工作溫度範圍	-20°C ~ +60°C		
Protection degree / 防水等級	IP64		
Wiring method / 出線方式	N/P : Ø4.2 x 2M / 3wires NP : Ø4.2 x 2M / 4wires		M8 connector / M8 接頭
Weight / 重量	Approx. 60g		Approx. 12g

◆ Dimensions / 尺寸圖 : (unit:mm)

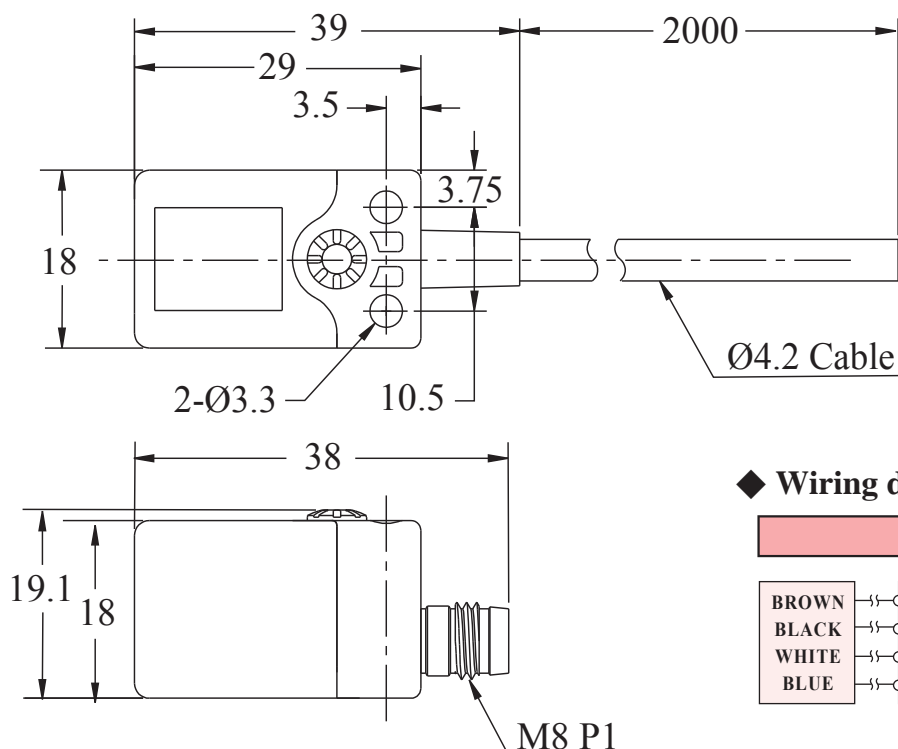

◆ Wiring diagrams / 接線圖 :

