

Series 101-A

- Cross Ref. : DE-STA-CO Series 201-U
- Holding Capacity: 110 lbs. (50 kg)
- Weight: 0.13 lb. (60 g)
- Bar opens 100°, Handle 56°
- Spindle Supplied: GH-FC-10138

One of the most affordable clamps. T-handle and straight base options available.

Model	Description
GH-101-A	U-Bar, Flanged Base, Straight Handle
GH-101-ASS	Stainless Steel Model of GH-101-A
GH-101-AI	U-Bar, Straight Base, Straight Handle
GH-101-AIT	U-Bar, Straight Base, T-Handle
GH-101-AT	U-Bar, Flanged Base, T-Handle

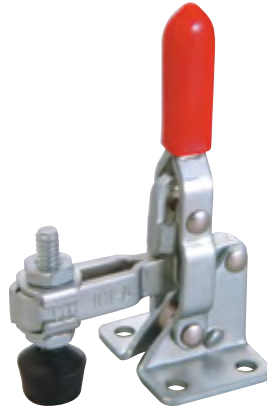

GH-101-A

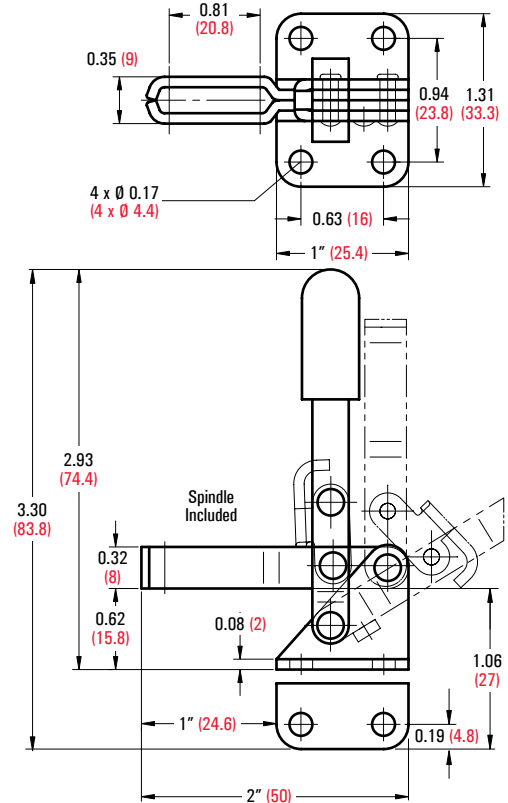

UNIT: inch (metric mm)

Series 11002-B

GH-13002-B has hardened bushings and removable ground pins.

Unique hole pattern for flexibility in a wide range of mounting options.



GH-13002-B

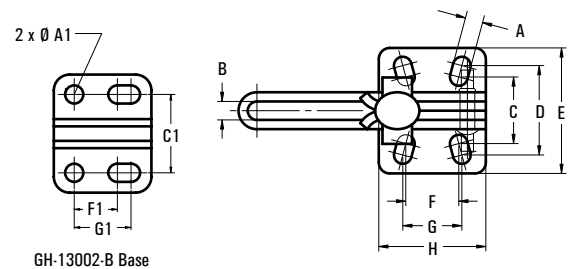

GH-13002-B Base

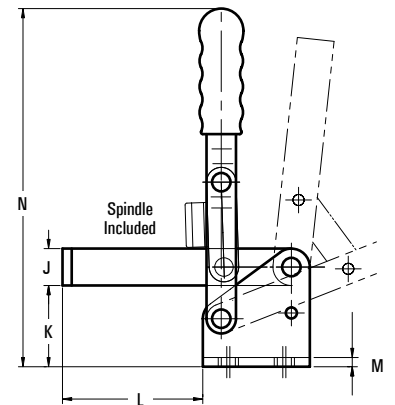

Model	Holding Capacity	Spindle Supplied	Bar Opens	Handle Opens	A	A1	B	C	C1	D	E	F	F1	G	G1	H	J	K	L	M	N	Weight
GH-11002-B	165 lbs. (75 kg)	GH-SA-10118	96°	66°	0.22 (5.6)	-	0.20 (5)	0.70 (18)	-	0.95 (24.2)	1.34 (34)	0.56 (14.3)	-	0.63 (16)	-	1.14 (29)	0.39 (10)	0.87 (22)	1.50 (38)	0.10 (2.5)	3.82 (97)	0.28 lb. (128 g)
GH-12002-B	330 lbs. (150 kg)	GH-SA-14134	108°	70°	0.22 (5.6)	-	0.25 (6.4)	1" (25.4)	-	1.06 (27)	1.65 (42)	0.50 (12.7)	-	0.75 (19)	-	1.38 (35)	0.51 (13)	1.12 (28)	1.73 (44)	0.13 (3.2)	5.63 (143)	0.37 lb. (170 g)
GH-13002-B	550 lbs. (250 kg)	GH-SA-56212	106°	67°	-	0.32 (8)	0.35 (8.8)	-	1.32 (33.5)	-	2.01 (51.1)	-	0.75 (19)	-	1" (25)	1.69 (43)	0.75 (19)	1.38 (35)	3.94 (100)	0.13 (3.2)	7.72 (196)	0.84 lb. (380 g)

UNIT: inch (metric mm)