

PTB-2.5, 5, 10, 20, 40BL₃

Model	Static friction torque(Nm)	Rated voltage(DC-V)	Power consumption at 75°C(W)	Mass(kg)
PTB-2.5BL ₃	25	24	30	11
PTB-5BL ₃	50	24	54	17
PTB-10BL ₃	100	24	52.8	34.5
PTB-20BL ₃	200	24	66	51.5
PTB-40BL ₃	400	24	92	85

PTB-2.5BL₃~20BL₃

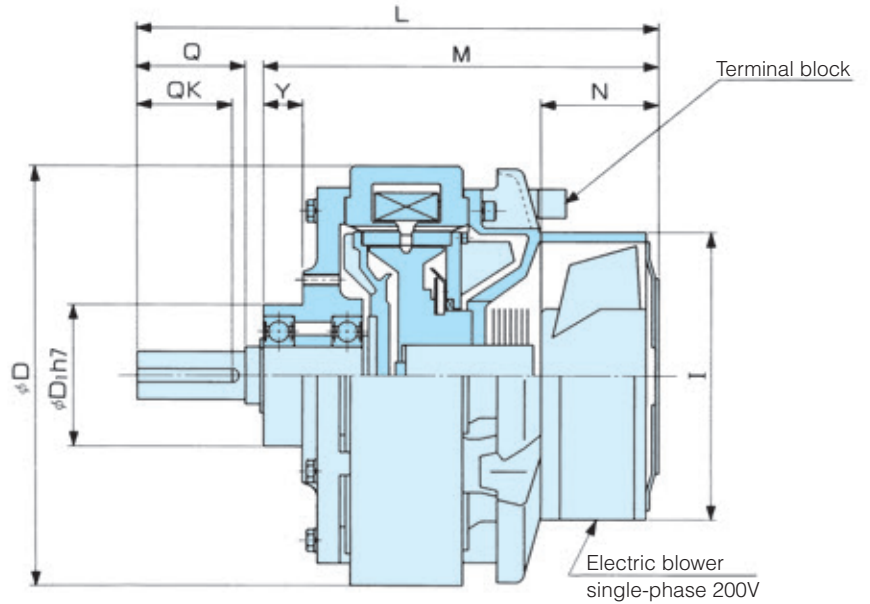
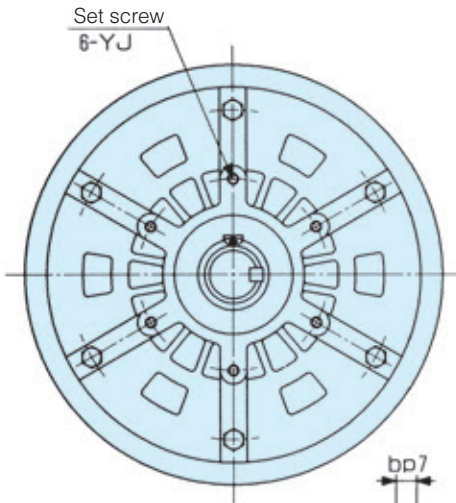

PTB-40BL₃

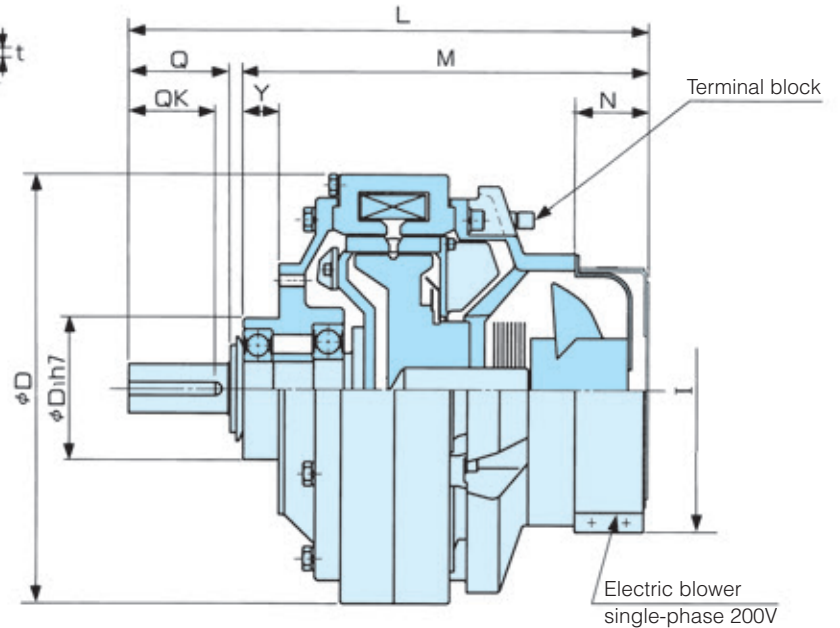
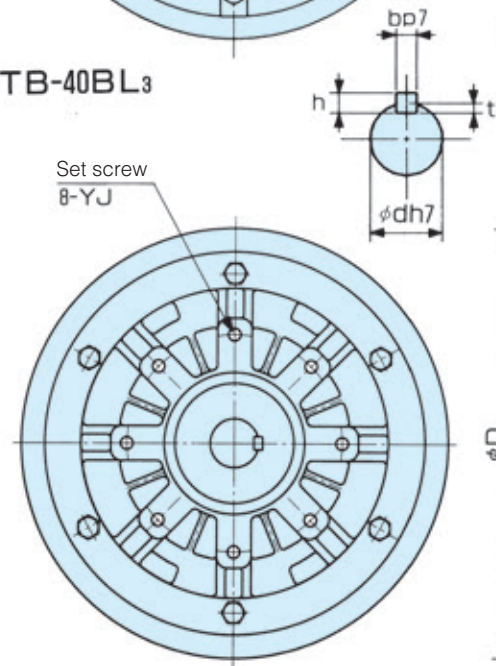

Model	Diameter direction			Shaft direction				Attachment		Shaft end					
	D	D1	I	L	M	N	Y	P.C.D	Tap	Q	QK	d	b	h	t
PTB-2.5BL ₃	182	55	120	221.5	169.5	43	15	78	M6×13	43	38	20	5	5	3
PTB-5BL ₃	219	74	∅150	274.5	208	61.5	23	100	M6×13	57	47	25	7	7	4
PTB-10BL ₃	290	100	∅150	335	257	61.5	25	140	M10×18	67	56	30	7	7	4
PTB-20BL ₃	335	110	∅150	352.5	269.5	61.5	25	150	M10×18	71	60	35	10	8	4.5
PTB-40BL ₃	395	130	∅268	482	376	68	33	200	M12×20	92	80	45	12	8	4.5