

PHB-0.6, 1.2, 2.5, 5, 10, 20

Model	Static friction torque(Nm)	Rated voltage(DC-V)	Power consumption at75°C(W)	Mass(kg)
PHB-0.6	6	24	22.5	4.0
PHB-1.2	12	24	23	5.0
PHB-2.5	25	24	30	9.0
PHB-5	50	24	54	15
PHB-10	100	24	52.8	38
PHB-20	200	24	66	48

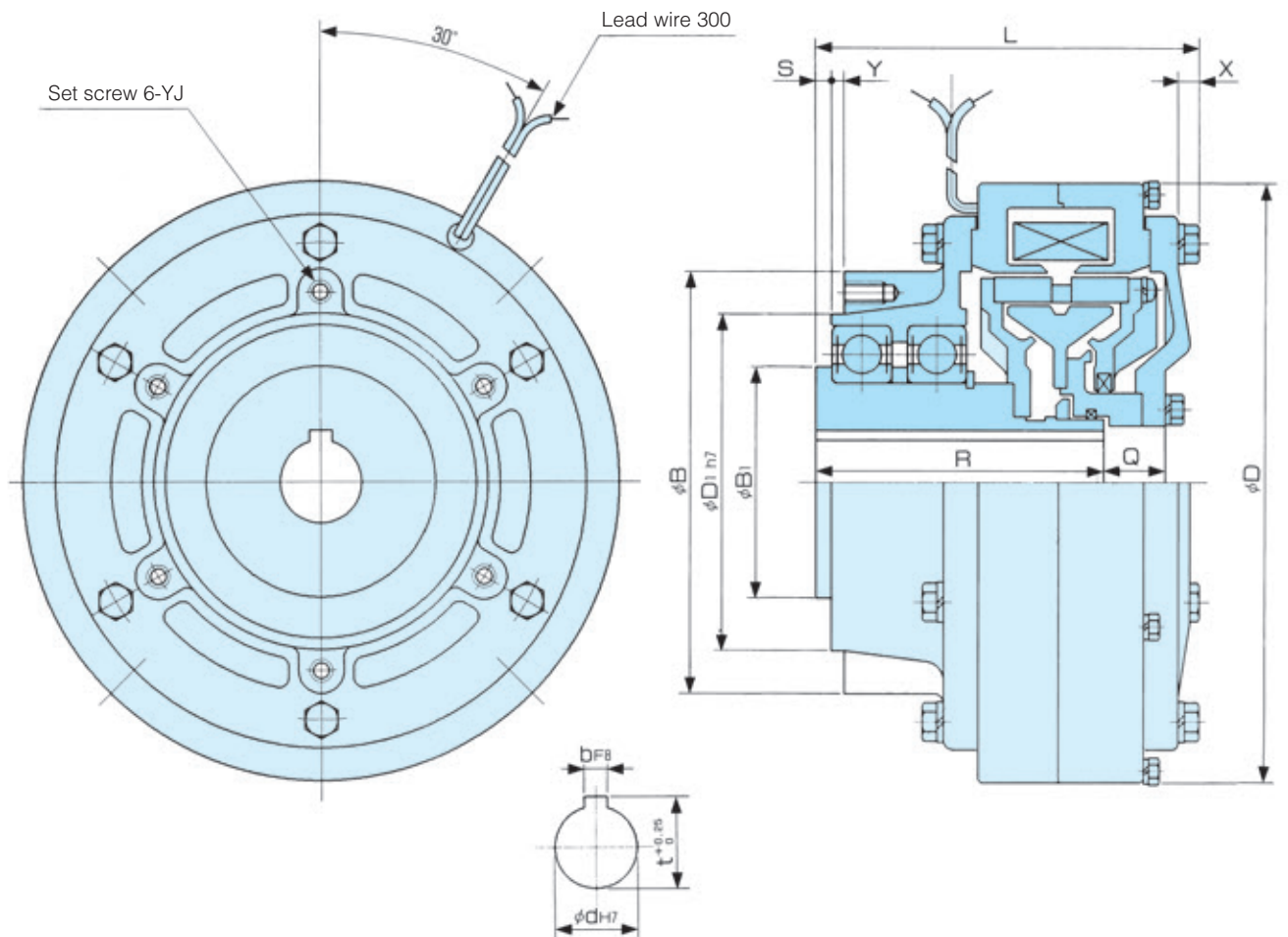

Model	Diameter direction				Shaft direction						Attachment		Shaft hole		
	B	B1	D	D1	L	R	Q	S	Y	X	K	KJ	d	b	t
PHB-0.6	90	45	134	70	82.3	59.5	18	2	3	4.8	80	M5×12	12	4	13.5
PHB-1.2	102	45	152	75	85	59	21	5	4	5.5	88	M6×10	15	5	17
PHB-2.5	129	70	182	102	116	87	19.5	5	4	5.5	115	M6×12	25	7	28
PHB-5	157	85	219	128	133	95.5	35.5	6.5	5	5.5	140	M6×15	32	10	35.5
PHB-10	210	100	290	160	160	114	28.5	5	5	7.5	180	M8×20	42	12	45.5
PHB-20	244	120	335	190	188	130	50	5	5	11	220	M10×20	55	15	60