

PMC-10, 20A₃

Model	Static friction torque(Nm)	Rated voltage(DC-V)	Power consumption at 75°C(W)	Mass(kg)
PMC-10A ₃	1	24	13.5	0.90
PMC-20A ₃	2	24	15	1.34

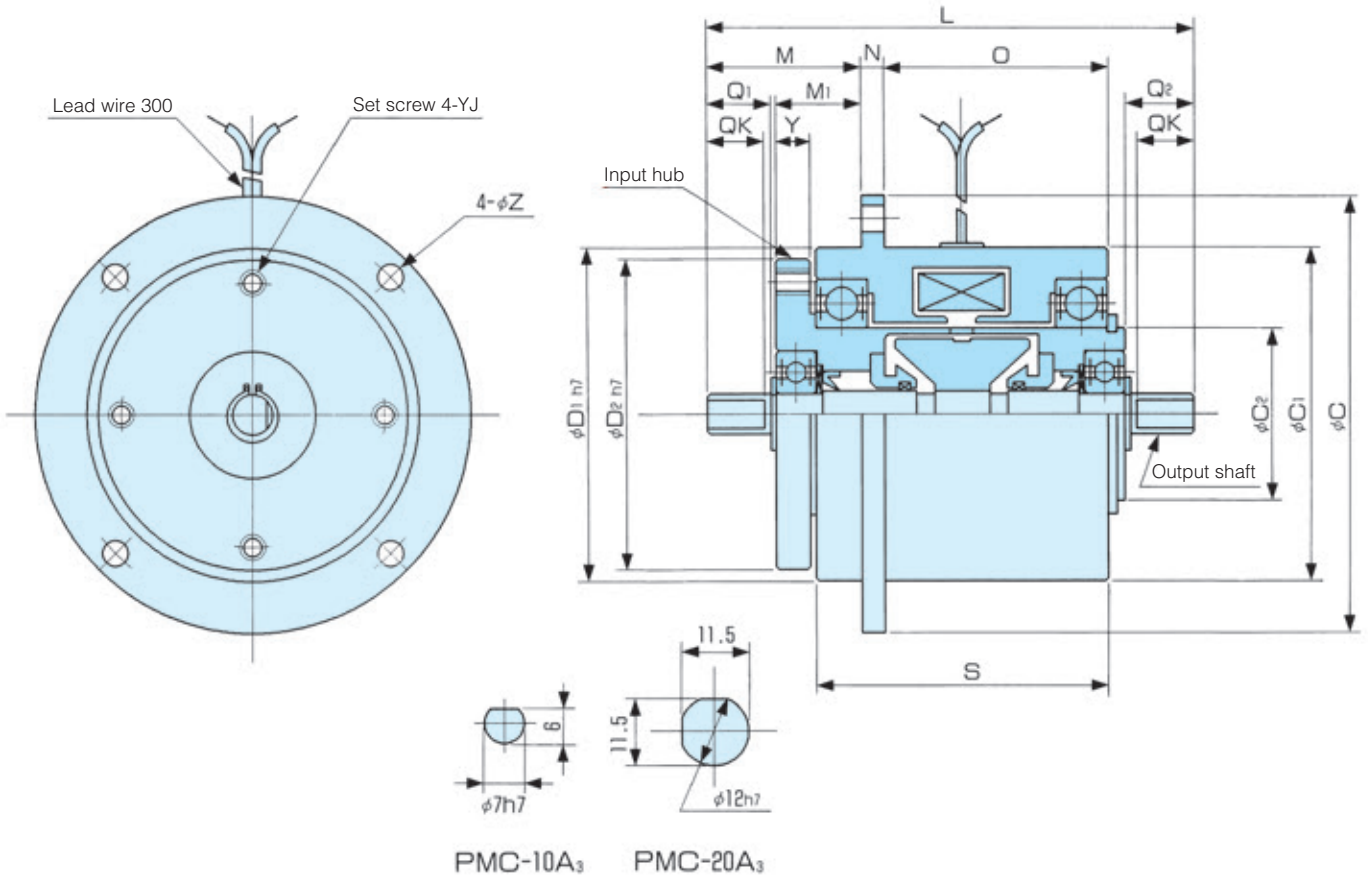

Model	Diameter direction					Shaft direction							Attachment				Shaft end		
	C	C1	C2	D1	D2	L	M	M1	N	O	S	Y	P.C.D	Hole	P.C.D	Tap	Q1	Q2	QK
PMC-10A ₃	76	58	30	58	54	85	27	15	4	39	51	6	68	4.5	46	M4×6	11	12	10
PMC-20A ₃	92	69	35	69	54	116	47	22	4	32	51	6	82	4.5	46	M4×6	24	25	20