

## JB-0.6, 1.2, 2.5, 5 Through Shaft Type

| Model  | Static friction torque(Nm) | Rated voltage(DC-V) | Power consumption at75°C(W) | Mass(kg) |
|--------|----------------------------|---------------------|-----------------------------|----------|
| JB-0.6 | 6                          | 24                  | 8                           | 0.8      |
| JB-1.2 | 12                         | 24                  | 11                          | 1.4      |
| JB-2.5 | 25                         | 24                  | 16                          | 2.6      |
| JB-5   | 50                         | 24                  | 23                          | 4.2      |

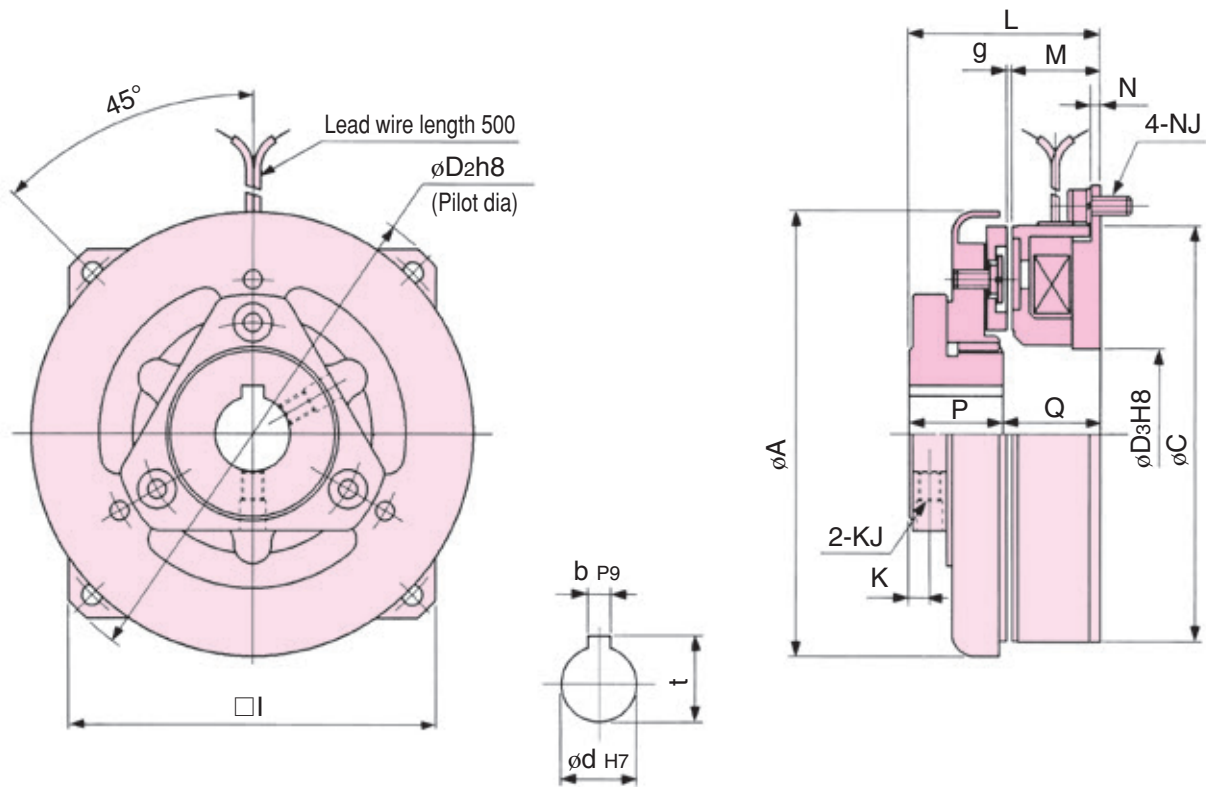

(DIM: mm)

| Model  | Diameter direction |       |     |    |     | Shaft direction |      |     |    |
|--------|--------------------|-------|-----|----|-----|-----------------|------|-----|----|
|        | A                  | C     | D2  | D3 | I   | L               | M    | N   | P  |
| JB-0.6 | 76                 | 70.3  | 88  | 25 | 66  | 40              | 21   | 2   | 18 |
| JB-1.2 | 96                 | 90.4  | 108 | 33 | 80  | 43              | 21   | 2   | 21 |
| JB-2.5 | 118                | 110.5 | 132 | 45 | 98  | 51              | 24.5 | 2.5 | 25 |
| JB-5   | 145                | 135.6 | 163 | 54 | 120 | 57              | 26.5 | 3   | 28 |

| Model  | Shaft direction |     | Attachment |    |       |       | Shaft hole |   |                                   |
|--------|-----------------|-----|------------|----|-------|-------|------------|---|-----------------------------------|
|        | Q               | g   | K          | KJ | NJ    |       | d          | b | t                                 |
|        |                 |     |            |    | P.C.D | Bolt  |            |   |                                   |
| JB-0.6 | 22              | 0.4 | 4.2        | M4 | 79    | M4×10 | 12         | 4 | 13.8 <sup>+0.1</sup> <sub>0</sub> |
| JB-1.2 | 22              | 0.4 | 4.7        | M5 | 99    | M4×10 | 15         | 5 | 17.3 <sup>+0.1</sup> <sub>0</sub> |
| JB-2.5 | 26              | 0.5 | 5.5        | M6 | 121   | M5×12 | 20         | 6 | 22.8 <sup>+0.1</sup> <sub>0</sub> |
| JB-5   | 29              | 0.5 | 6          | M6 | 149   | M6×16 | 25         | 8 | 28.3 <sup>+0.2</sup> <sub>0</sub> |