

スタンド/ハンガーピン/支持パイプ/引掛スパナ
Stand (S) (L)/Hanger Pin/Stand Pipe/Round Nut Spanner

スタンド **Stand (S) (L)**

Type STD-S / SD3 (27.2 / 19)

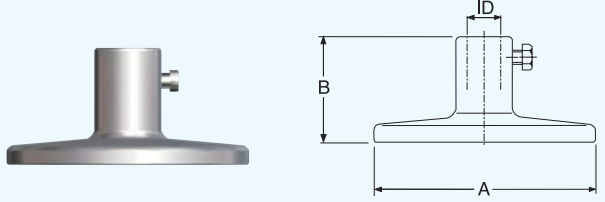

Nom.size(Type)	ID	A	B	Mass kg
STD-S	19.2	125	60	1.05

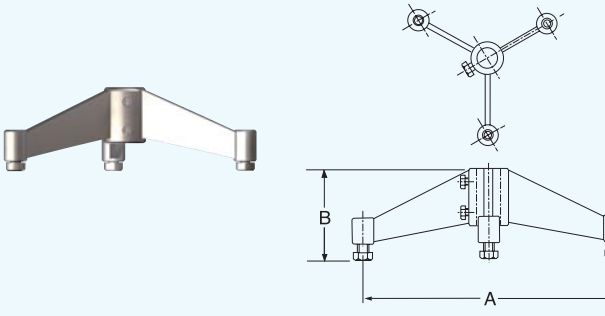

Nom.size(Type)	ID	A	B	Mass kg
SD3-27.2	27.6	298	調整範囲 93~113	1.5
SD3-19	19.3	200	調整範囲 74~94	0.9

ハンガーピン **Hanger Pin**

Type PN-M10 / Type PN-M12

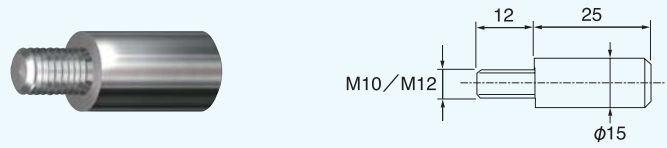

Mass kg
0.055

支持パイプ **Stand Pipe**

Type PSP

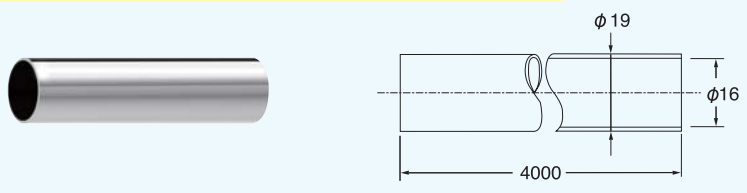

Mass kg
2.140

引掛スパナ **Round Nut Spanner**

Type SP-R

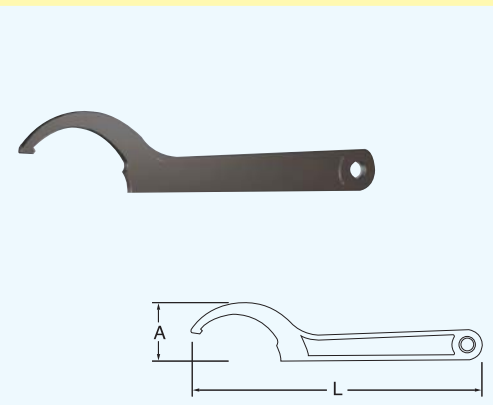

Nom.size(Type)	A	L	Mass kg	適用例		
				溝付丸ナット	2方ボールバルブ	3方ボールバルブ
45 - 48	36	193	0.15	1.0 ^S	—	—
52 - 55	41	207	0.19	—	—	—
58 - 65	46	230	0.26	1.5 ^S	1.0 ^S	1.0 ^S
70 - 75	52	246	0.44	2.0 ^S	—	1.5 ^S
80 - 85	62	269	—	—	1.5 ^S	1.0 ^S
92 - 98	68	283	0.47	2.5 ^S	—	2.0 ^S ・1.5 ^S
105 - 115	84	333	0.72	3.0 ^S	2.0 ^S	2.5 ^S
120 - 130	83	332	0.70	3.5 ^S	2.5 ^S	3.0 ^S ・2.0 ^S
140 - 150	96	384	1.00	4.0 ^S	3.0 ^S	3.5 ^S ・4.0 ^S ・2.5 ^S
155 - 165	98	380	1.00	—	3.5 ^S	3.0 ^S
175 - 195	128	465	2.70	—	4.0 ^S	3.5 ^S
200 - 220	132	463	2.60	—	—	4.0 ^S

Photo is 3DCG.