

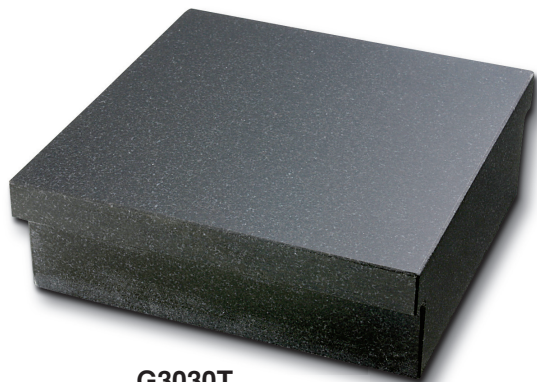

# GRANITE SURFACE PLATE T TYPE



G3030T



T-shape for easy lifting

## DIMENSIONS

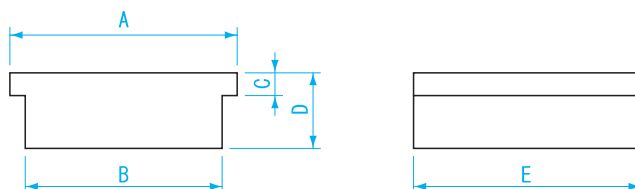

Units : mm

Model No.	A	B	C	D	E
G3030T	300	260	30	100	300
G3045T	450	410	30	100	300

- USE**
- Measurement of flatness, parallelism and squareness
  - For tooling set up, precision inspection, etc.

**MATERIAL**

- Granite

**FEATURES**

- Convenient to lift and move
- Granite is abrasion resistant and unlike cast iron, granite does not rust or deteriorate with time

Order No.	Model No.	W × D × H (mm)	Flatness (μm)	Weight
150710	G3030T	300 × 300 × 100	3.5	22kg
150711	G3045T	300 × 450 × 100	4.5	40kg

# GRANITE COMPARATOR STAND



GC-150C

GC-200C

## DIMENSIONS

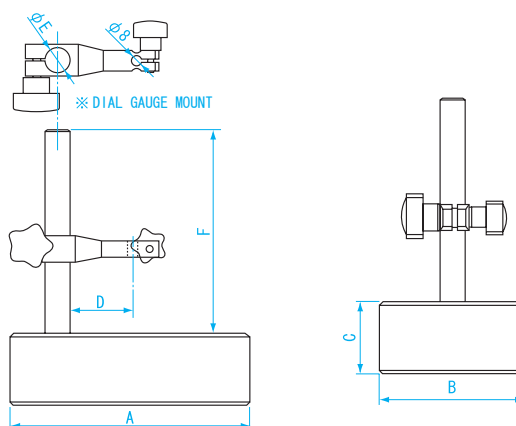

Units : mm

Model No.	A	B	C	D	E	F
GC-150C	150	100	40	45	18	150
GC-200C	200	150	50	65	30	300

- USE**
- Provides flat surface for dial indicator measurements

**MATERIAL**

- Granite

**FEATURES**

- Granite is abrasion resistant. Unlike cast iron, granite does not rust or deteriorate with time

Order No.	Model No.	Measuring Range (mm)	Flatness(base) (μm)	Dial Indicator Mounting hole (mm)	Weight
NEW 150973	GC-150C	0 ~ 100	2	φ 8	2.5kg
NEW 150974	GC-200C	0 ~ 250	2	φ 8	7.5kg