

RoHS対応

ERON®

PLAIN CLAMPS

No.E-405

プレーンクランプ

材質 S45C

熱処理 焼入HRC30±5

表面処理 黒染め

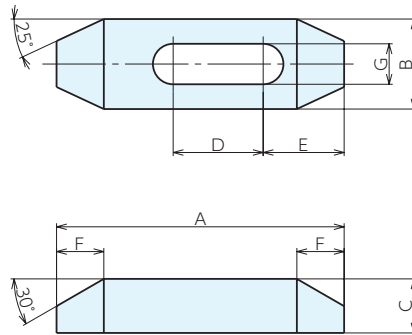

仕様・価格表

1個価格

オーダーNo.	No.	適合ボルト	A	B	C	D	E	F	G	質量kg	価格
01107	PC00101	M 8	60	25	12	21	20	11	9	0.06	1,790
02032	PC00102	M 8	100	25	16	38	23	14	9	0.12	2,260
02033	PC00103	M 8	150	25	19	56	27	17	9	0.25	3,100
02034	PC00201	M10	60	25	12	19	22	11	11	0.06	1,790
02037	PC00202	M10	100	25	16	38	25	14	11	0.12	2,260
02040	PC00203	M10	150	25	19	56	28	17	11	0.25	3,100
02041	PC00301	M12	60	25	12	18	23	11	13	0.08	2,040
02048	PC00302	M12	100	32	19	32	28	17	13	0.16	2,580
02060	PC00303	M12	150	32	22	51	33	19	13	0.29	3,050
02392	PC00401	M16	60	32	16	10	25	14	18	0.08	2,160
02393	PC00402	M16	100	38	19	31	31	17	18	0.19	2,760
02394	PC00403	M16	150	38	22	48	33	19	18	0.36	3,100
02395	PC00501	M20	100	38	19	27	31	17	22	0.18	3,200
02396	PC00502	M20	150	38	25	48	38	22	22	0.37	3,510
02397	PC00503	M20	200	50	30	56	41	25	22	0.73	5,000
02398	PC00601	M22	150	50	32	42	44	27	24	0.63	5,500
02462	PC00602	M22	200	50	32	48	47	30	24	1.00	8,050
02475	PC00603	M22	250	50	38	77	52	33	24	1.34	9,250
02523	PC00701	M24	150	50	32	42	46	27	26	0.58	5,500
02540	PC00702	M24	200	50	32	48	49	30	26	0.95	8,050
02541	PC00703	M24	250	50	38	77	52	33	26	1.28	9,250

使用例

