



# MTC 超ロングスリムチャックホルダ

## SUPER LONG SLIM CHUCK HOLDER



### 特長 Features

- ◆ 干渉を考慮した胴径スリムチャック仕様。  
Less interference with slim body.
- ◆ 深い穴加工に標準ドリルを使用出来コスト削減が可能になります。  
Standard drill can be used for deep hole drilling. It helps cost reduction.
- ◆ 抜群の振れ精度5 $\mu$ m以下。  
High precision. (less than 5 $\mu$ m)
- ◆ 刃物脱着が容易、高価な専用装置が不要です。  
Easy chucking and removing.  
No expensive special Equipment required.
- ◆ シンプル構造で作業性UP。  
Simple structure, workability improvement.
- ◆ エンドミル用は金型仕上加工に最適。  
Endmill type is suitable for finish die machining.

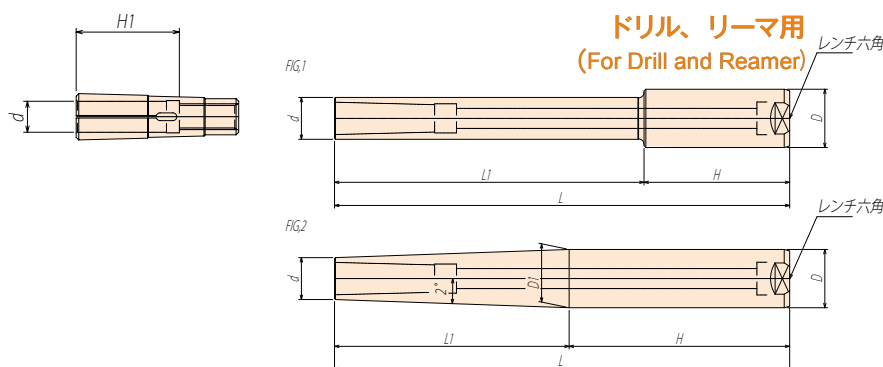

### エンドミル用 (For Endmill)

### ドリル、リーマ用 (For Drill and Reamer)

CODE	FIG	d	D	L	L1	H	Collet	Wrench
ST20-MTC 8-100	1	17	20	100	40	60	MTC8	3mm 六角
-150				150	90			
-200				200	140			
ST32-MTC 12-150	1	23	32	150	70	80	MTC12	5mm 六角
-200				200	120			
-250				250	170			
-300				300	220			
ST32-MTC 20-200	1	40	32	200	120	80	MTC20	8mm 六角
-250				250	170			
-300				300	220			
-350				350	270			

### MTC コレット (Collet)

CODE	d	H1
MTC 8-6	6	26
-8	8	
MTC 12-6	6	30
-8	8	
-10	10	
-12	12	40
MTC 20-6	6	
-8	8	30
-10	10	
-12	12	
-16	16	45
-20	20	
-20	20	55
-20	20	

### エンドミル用 (For Endmill)

CODE	FIG	d	D	L	L1	H	D1	Collet	Wrench
ST20-MTC 8E-100	2	17	20	100	43	57	20	MTC8	3mm 六角
-150				150		107			
-200				200		157			
ST32-MTC 12E-150	2	23	32	150	129	80	32	MTC12	5mm 六角
-200				200		71			
-250				250		121			
-300				300		171			
ST32-MTC 20E-200	2	40	32	200	200	80	47	MTC20	8mm 六角
-250				250		170			
ST42-MTC 20E-300				2		42			
-350	350	250	58						

■ 特殊サイズも注文により製作いたします。 Special size is available upon request.