

Dial Test Indicators

SERIES 513 — Universal Type

FEATURES

- Universal application for all directions. Not only the direction of the measuring point, but also the direction of measurement itself can be adjusted 360 degrees without moving the indicator.

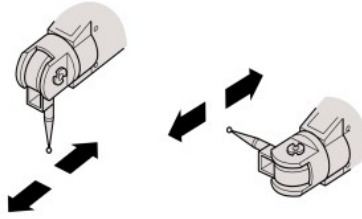

513-304GE

SPECIFICATIONS

Metric

Graduation	Order No.		Range	Accuracy	Dial reading	Measuring force	 Jeweled bearing type
	Basic set	Full set					
0.01mm	513-304GE	513-304GT	0.8mm	8μm	0-40-0	0.3N or less	 ✓

Inch

Graduation	Order No.		Range	Accuracy	Dial reading	Measuring force	 Jeweled bearing type
	Basic set	Full set					
.0005"	513-302G	513-302GT	.03"	±.0005"	0-15-0	0.3N or less	 ✓

DIMENSIONS AND MASS

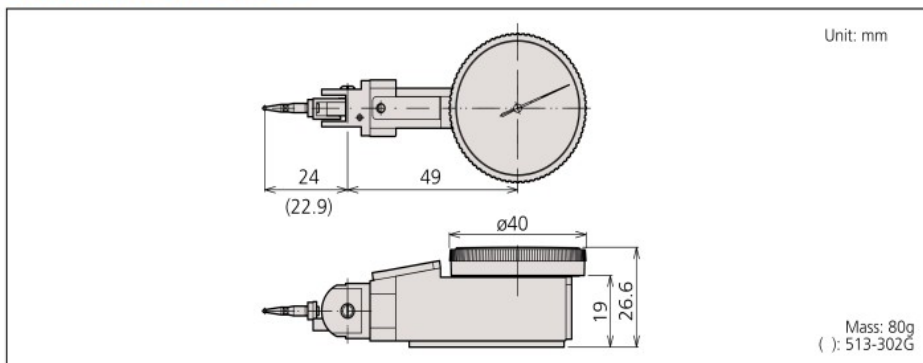

Set Configuration: Metric

Full set



Basic set

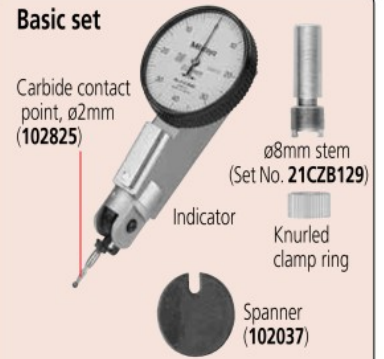

Set Configuration: Inch

Full set



Basic set

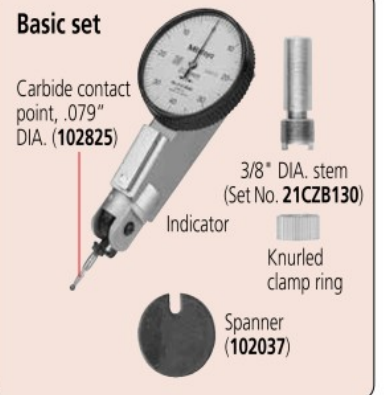

Optional Accessories

- : Swivel clamp
- : Holding bar
- : Stem