

Dial Depth Gage

SERIES 527 — With Fine Adjustment

FEATURES

- Easier and faster reading of dial.
- Made of hardened stainless steel.
- Base and measuring faces are hardened and micro-lapped.
- Optional wider extension base are available.



527-313-50

SPECIFICATIONS

Inch

Range	Order No.	Dial reading	Accuracy	Mass (g)
0 - 6"	527-311-50	.001"	±.001"	280
0 - 8"	527-312-50	.001"	±.001"	300
0 - 12"	527-313-50	.001"	±.0015"	340

DIMENSIONS

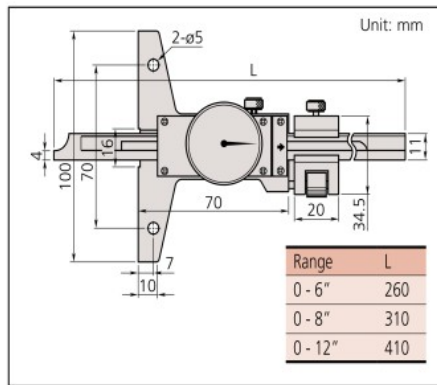

Technical Data

Dial reading: .001"
Base size: 100x6.5mm (WxT)

Extension Bases

Optional Accessory for Depth Gage

FEATURES

- Attached to the base (reference face) plate of a depth gage to extend its span.
- These extension base cannot be attached to 0-24" and 0-40", 0-600mm, 0-1000mm, range models.



900372

SPECIFICATIONS

Metric

Size	Order No.	Remarks (dimension a, b / n)
180mm	900370	70mm, 55mm 2
260mm	900371	35mm, 60mm 5
320mm	900372	70mm, 55mm 4

Inch

Size	Order No.	Remarks (dimension a, b / n)
7"	900367	2.76", 2.17" 2
10"	900368	1.38", 2.36" 5
12"	900369	2.76", 2.17" 4

DIMENSIONS

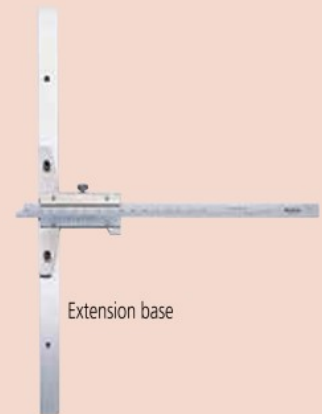
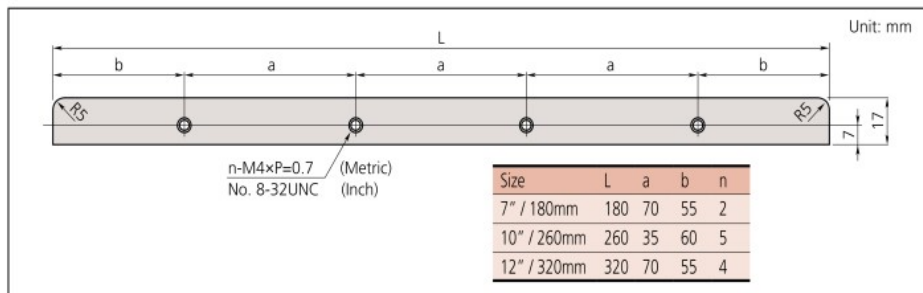

Extension base

Attaching the extension base

