

Depth Micrometer

SERIES 128

Technical Data

Accuracy: $\pm 3\mu\text{m}$ for micrometer head feed
 Graduation: .001" or 0.01mm
 Flatness of reference face: $1.3\mu\text{m}$ for 63.5mm width base,
 $2\mu\text{m}$ for 101.6mm width base
 Flatness of measuring rod face: $0.3\mu\text{m}$
 Parallelism between reference face and measuring rod face:
 $(4+L/50)\mu\text{m}$, L=Max. measuring length (mm)
 Measuring rod diameter: 4mm

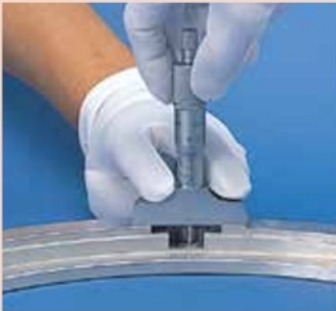

FEATURES

- $\varnothing 4\text{mm}$ measuring rod.
- With measuring rod clamp.

- Carbide-tipped measuring rod model is available.
- With ratchet stop for constant force.

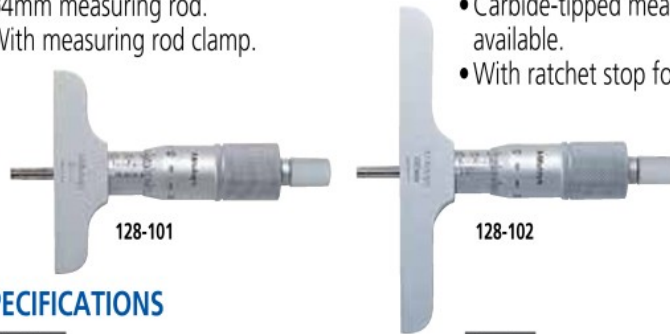

SPECIFICATIONS

Metric		
Range	Order No.	Remarks (base)
0 - 25mm	128-101	63.5x16mm
0 - 25mm	128-103*	63.5x16mm
0 - 25mm	128-102	101.6x16mm
0 - 25mm	128-104*	101.6x16mm

Inch		
Range	Order No.	Remarks (base)
0 - 1"	128-105	2.5" x .63"
0 - 1"	128-106	4" x .63"

*with carbide-tipped measuring rod

Depth Micro Checker

SERIES 515

FEATURES

- The Depth Micro Checker is designed to efficiently check the zero point of a depth micrometer.



SPECIFICATIONS

Metric		
Range	Order No.	Remarks (length to check)
0 - 150mm	515-570	25, 50, 75, 100, 125, 150mm
0 - 300mm	515-571	25, 50, 75, 100, 125, 150, 175, 200, 225, 250, 275, 300mm

Inch		
Range	Order No.	Remarks (length to check)
0 - 6"	515-575	1", 2", 3", 4", 5", 6"

DIMENSIONS

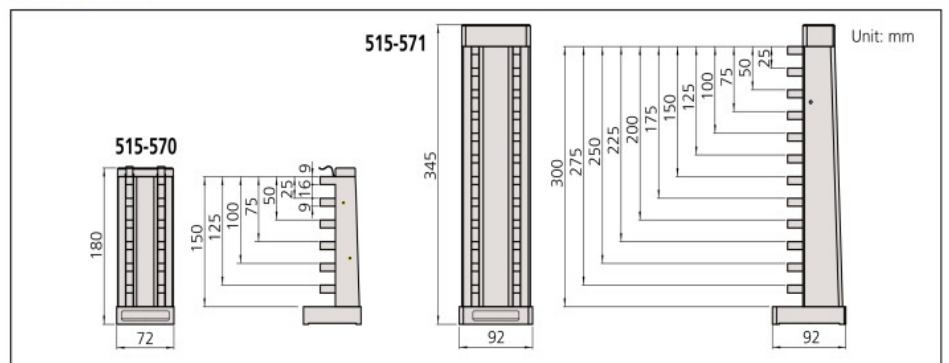

Technical Data

Block pitch accuracy: $\pm(1+L/150)\mu\text{m}$,
 L=Length to check (mm)
 Anvil block accuracy: $\pm 0.5\mu\text{m}$

