

Vernier Height Gage

SERIES 506 — Light-Weight Height Gage

FEATURES

- The Light-Weight Height Gage is designed for scribing from a vertical base or for small parts.
- Satin chrome-finished scales for glare-free reading.
- Beam and slider are made of stainless steel.
- Carbide-tipped scriber is provided.



SPECIFICATIONS

Metric				
Range	Order No.	Accuracy	Graduation	Mass (kg)
0 - 200mm	506-207	±0.03mm	0.02mm	1.4

Inch/Metric				
Inch model with inch/metric double scale				
Range	Order No.	Accuracy	Graduation	Mass (kg)
0 - 8" / 0 - 200mm	506-208	±.001"	.001" / 0.02mm	1.4

DIMENSIONS

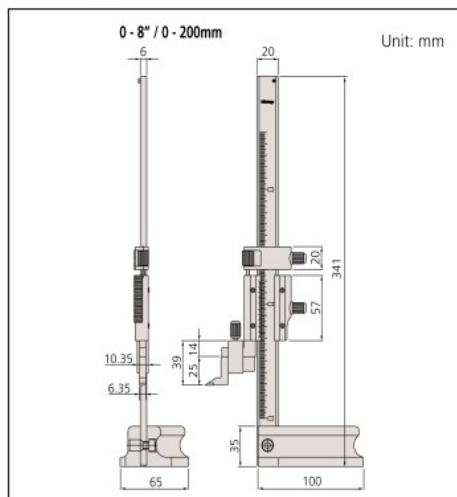

Standard Scriber Provided

Carbide-tipped scriber (900173) and scriber clamp (901338)

Dimension of scriber

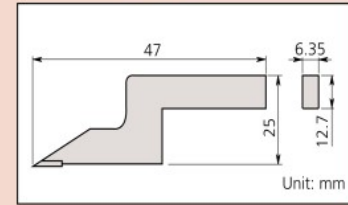

Optional Accessories

- 953639: Holding bar for test indicator (length: 2" / 50mm)
- 900322: Swivel clamp used with holding bar

