



511-786

### Technical Data

Accuracy:  $2\mu\text{m} / .00008''$   
 Indication stability:  $1\mu\text{m} / .00004''$   
 Graduation: 0.01mm, 0.001mm, .0005" or .0001"

### Contact Point

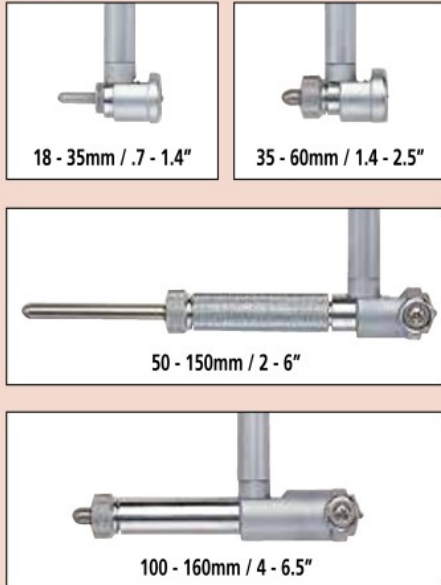

# Bore Gages

## SERIES 511 — Short-Leg Type

### FEATURES

- Compact and lightweight because of the short length below the grip.
- Carbide-tipped contact point for durability.

### SPECIFICATIONS

Inch		Gage Stem $\phi 3/8''$		
Measuring Range	Order No. With 2922SB Graduation .0005"	Order No. With 2923SB-10 Graduation .0001"	Number of Anvils	Number of Spacers
.7 - 1.4"	511-786	511-791	9	2
1.4 - 2.5"	511-787	511-792	6	4
2.0 - 6.0"	511-788	511-793	11 (2" sub anvil)	4
4.0 - 6.5"	511-789	511-794	13	4

Metric		Gage Stem $\phi 8\text{mm}$		
Measuring Range	Order No. With 2046SB Graduation 0.01mm	Order No. With 2109SB-10 Graduation 0.001mm	Number of Anvils	Number of Spacers
18 - 35mm	511-766	511-771	9	2
35 - 60mm	511-767	511-772	6	4
50 - 150mm	511-768	511-773	11 (50mm Sub Anvil)	4
100 - 160mm	511-769	511-774	13	4

### DIMENSIONS

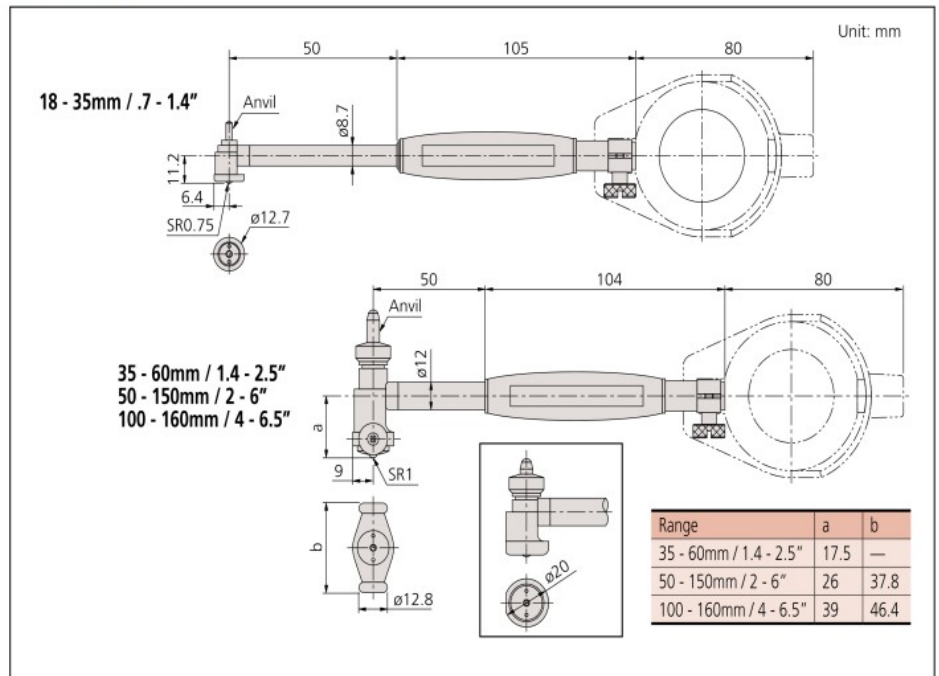

### Optional Accessories

----: Setting ring (See page C-29.)