

# Bore Gages

## SERIES 511 — for Small Holes

### FEATURES

- Interchangeable anvils are made of alloy steel.
- The dial indicator is fully protected by a rugged cover.

### SPECIFICATIONS

**Metric** Gage Stem  $\varnothing$  8mm

Measuring Range	Order No. Without Dial Gage	Order No. With 2046SB Graduation 0.01mm	Order No. With 2109SB-10 Graduation 0.001mm	Number of Anvils	Number of Spacers
6 - 10mm	511-209*	511-211	511-210	9	1
10 - 18.5mm	511-201*	511-204	511-203	9	1

\*Does not come with Dial Gage Protector Cover ( 21DZA000 )

**Inch** Gage Stem Dia .375"

Measuring Range	Order No. Without Dial Gage	Order No. With 2922SB Graduation .0005"	Order No. With 2923SB-10 Graduation .0001"	Number of Anvils	Number of Spacers
.24 - .4"	511-214*	511-213	511-212	9	1
.4 - .74"	511-205*	511-207	511-206	9	1

\*Does not come with Dial Gage Protector Cover ( 21DZA000 )

### DIMENSIONS

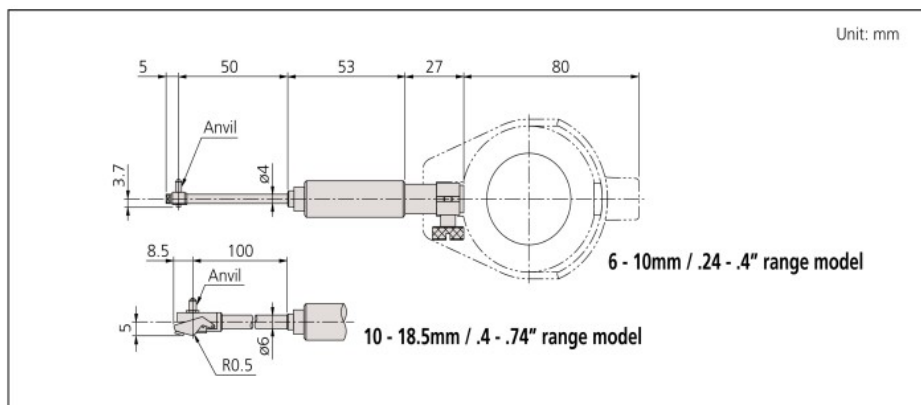

511-204

### Technical Data

Accuracy:  $5\mu\text{m} / .0002"$   
 Indication stability:  $2\mu\text{m} / .00008"$   
 Graduation: 0.01mm, 0.001mm, .0005" or .0001"

### Measuring Heads

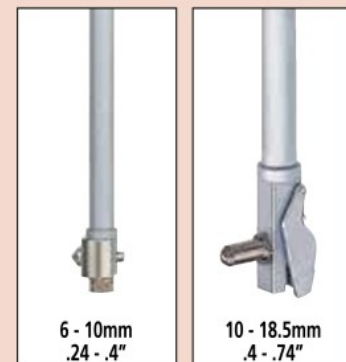

6 - 10mm  
.24 - .4"

10 - 18.5mm  
.4 - .74"

### Optional Accessories

21DZA000: Dial Gage Protector Cover  
 -----: Setting ring (See page C-29.)