

外形図

 CADデータ有り。お申し込みは **▶518P**

■HF-2MS (最適把持力 40N~70N)

HF-2MS 標準

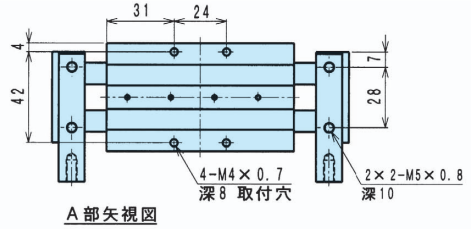
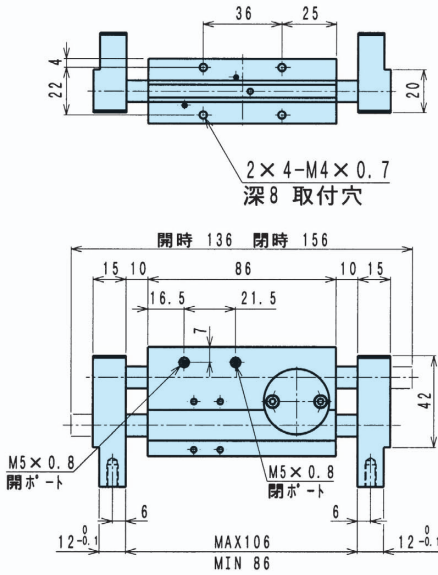

A部矢視図

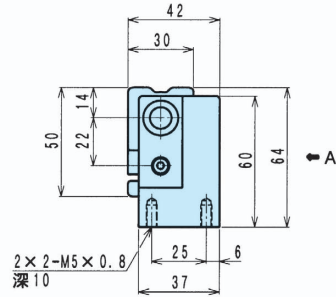

HF-2MS-E□S□

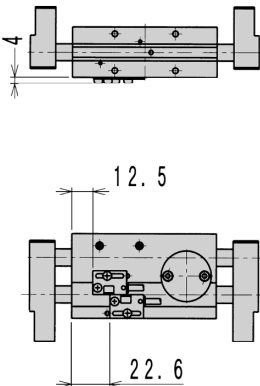

HF-2MS-B

