

# ZG530 □, ZG553 □

Products compliant with the EMC Directive



## Solid State Type Sensor Switch

### Applicable cylinders

- Slim cylinders ● Twinport cylinders ● GA ● ORC ● ORCA ● ORGA ● ORK<sup>Note</sup> ● MRG ● RAK
- Swing cylinders ● Twist cylinders

Note: Excluding ORK  $\phi$  16 [0.630in.].

### Specifications

Item	Model	ZG530 □	ZG553 □
Wiring type		2-lead wire	3-lead wire
Power supply voltage		—	DC4.5~28V
Load voltage		DC10~28V	DC4.5~28V
Load current		4~50mA	100mA MAX.
Consumption current		—	10mA MAX. (DC24V)
Internal voltage drop <sup>Note 1</sup>		4.5V MAX.	0.5V MAX. (At 50mA load current)
Leakage current		1mA MAX. (DC24V at 25°C [77°F])	50 $\mu$ A MAX. (DC24V)
Response time		1ms MAX.	
Insulation resistance		100M $\Omega$ MIN. (At DC500V Megger, between case and lead wire end)	
Dielectric strength		AC500V (50/60Hz) in 1 minute (Between case and lead wire end)	
Shock resistance <sup>Note 2</sup>		294.2m/s <sup>2</sup> [30G] (Non-repeated shock)	
Vibration resistance <sup>Note 2</sup>		88.3m/s <sup>2</sup> [9G] (Total amplitude 1.5mm [0.06in.], 10~55Hz)	
Environmental protection		IP67 (IEC standard), JIS C0920 (Water-proof type)	
Operation indicator		When ON: Red LED indicator lights up	
Lead wire <sup>Note 3</sup>		PVC 0.2SQ $\times$ 2-lead $\times$ $\ell$	PVC 0.2SQ $\times$ 3-lead $\times$ $\ell$
Ambient temperature		0~60°C [32~140°F]	
Storage temperature range		-10~70°C [14~158°F]	
Mass		20g [0.71oz.] (For lead wire length A: 1000mm)	

Notes: 1. The internal voltage drop depends on load current.

2. Measured by Koganei test standard.

3. Lead wire length  $\ell$ : A; 1000mm [39in.], B; 3000m [118in.]

### Internal Circuit

#### ZG530 □

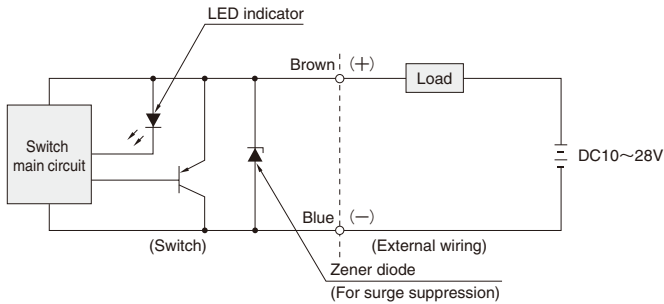

#### ZG553 □

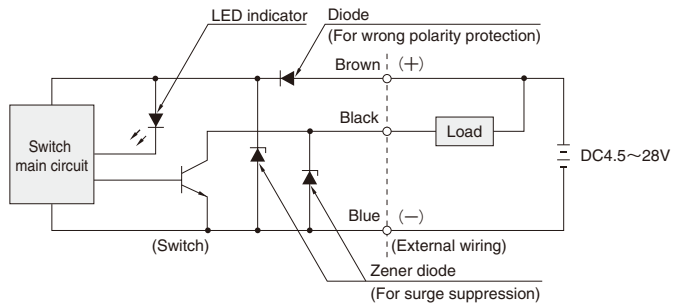

### Dimensions (mm)

#### ZG530 □

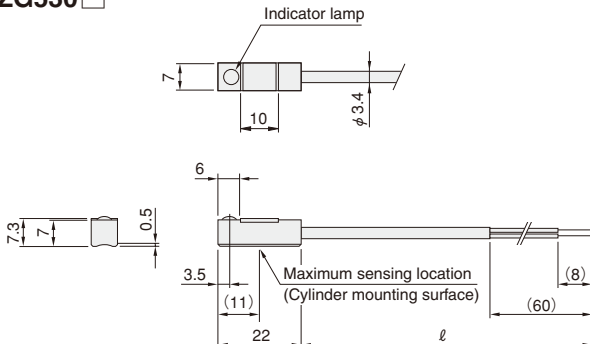

#### ZG553 □

