

Aluminum Core Type:
Swivel Caster in use of Silent
Bearing with Lock Brake

TRS-AWJB

Aluminum Core Type:
Swivel Caster in use of
Silent Bearing

TRS-AWJ

Aluminum Core Type:
Swivel Caster in use of
Silent Bearing with Double
Lock Brake

TR-AWJS

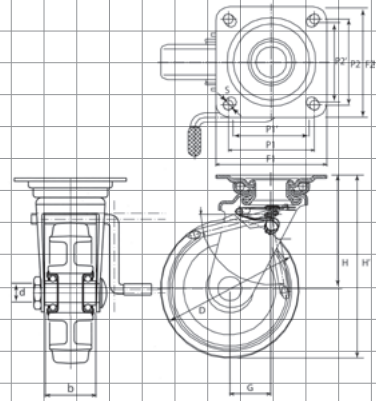
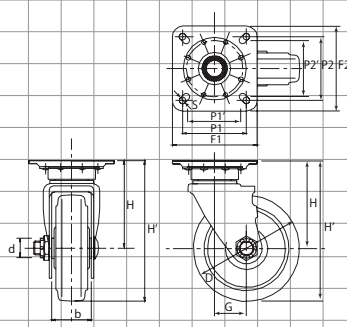
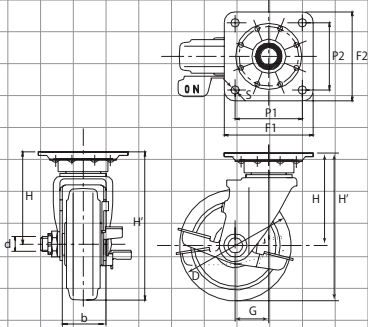
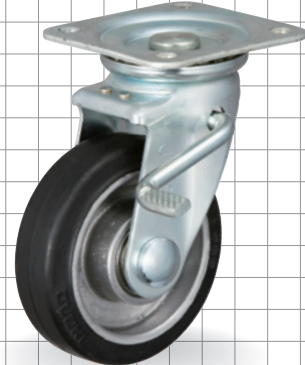
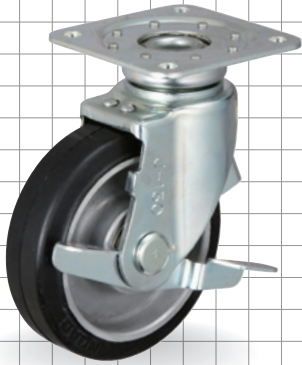

Product Name	Wheel diameter	Mounting Height	Bracket Height	Top plate	Hole pitch	Offset	Maximum load		Quantity per case
	D	H'	H	F1/F2	P1/P2	G	N	kg	Qty
TRS-150AWJB	150	198	123	120/120	90/90	45	1960	200	6

Product Name	Wheel diameter	Mounting Height	Bracket Height	Top plate	Hole pitch	Offset	Maximum load		Quantity per case
	D	H'	H	F1/F2	P1/P2	G	N	kg	Qty
TRS-150AWJ	150	198	123	120/120	90/90 (Oval Hole)	45	1960	200	6
TRS-200AWJ	200	250	150	140/140	112/112 (105/105)	58	2450	250	4

Product Name	Wheel diameter	Mounting Height	Bracket Height	Top plate	Hole pitch	Offset	Maximum load		Quantity per case
	D	H'	H	F1/F2	P1/P2	G	N	kg	Qty
TR-100AWJS	100	144	94	95/95	73/73 (70/70)	35	1176	120	16
TR-130AWJS	125	175	113	105/105	82/82 (79/79)	40	1764	180	8

For Safe Use

Casters for Middle-Size Loads

Low Starting Resistance Casters

Caster for Tow Trolleys