

TC-TBV

ALUMINUM AUTOMATIC TIGHTENERS

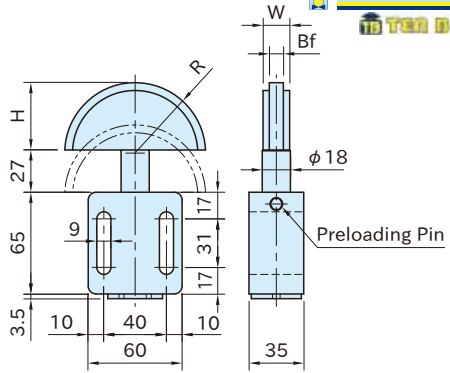

Body	Bushing	Sliding Block	Others
Aluminium Sandblasted	Brass	Ultrahigh molecular weight polyethylene	Steel Zinc plated

Part Number	Chain No.	Bf	W	R	H	Tension (N)	Weight (g)
TC-TBV40L	40	7	16	35	33	30~100	430
TC-TBV40M						60~170	
TC-TBV50L	50	9	17	45	43	90~250	

How To Use

Installation Instructions

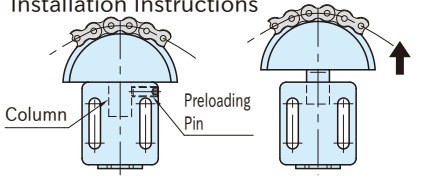

Technical Information:

- Operating Temperature max. 70°C
- Allowable Chain Speed 20m/min

Features:

- Can be used as automatic chain tighteners, automatic belt tighteners, shock absorbers.
- It keeps appropriate performance of chain or belt drives, and improves the life of the other components in the machinery.
- Preloading system simplifies the installation.
- Sliding block can turn 360 degrees.

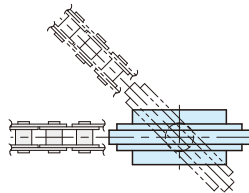

Press the column into the body, and put the preloading pin in the preloading hole on the body. Then tighten the pin into the hole. When you loosen the preloading pin, the spring inside the body starts to work and automatically apply tension to the chain.