

TC-BL

PLASTIC AUTOMATIC TIGHTENERS

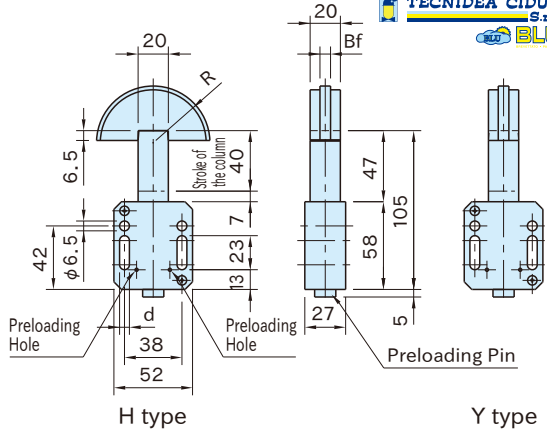

Body	Column	Sliding block	Bolt	Spring
Polyamide (glass-fiber reinforced) Blue	Polyamide (glass-fiber reinforced) Yellow	Ultrahigh molecular weight polyethylene (UHMWPE)	SUS304	SUS302

Part Number	Chain No.	Bf	R	d	Tension (N)	Weight (g)
TC-BL20-40H	40	7	37.5	6.5	47~108	130
TC-BL20-40Y						
TC-BL20-50H	50	9	40			
TC-BL20-50Y						
TC-BL30-40H	40	7	37.5	8.5	60~152	130
TC-BL30-40Y						
TC-BL30-50H	50	9	40			
TC-BL30-50Y						

Features:

- Can be used in humid environments, in contact with water or corrosive agents.
- Can be used as automatic chain tighteners, automatic belt tighteners, shock absorbers.
- It keeps appropriate performance of chain or belt drives, and improves the life of the other components in the machinery.
- Preloading system simplifies the installation.

Technical information:

- Operating Temperature max. 70°C
- Allowable Chain Speed 20m/min

