

SKPZN

CLAMP PLATES



SKPZN04-12



SKPZN09-16

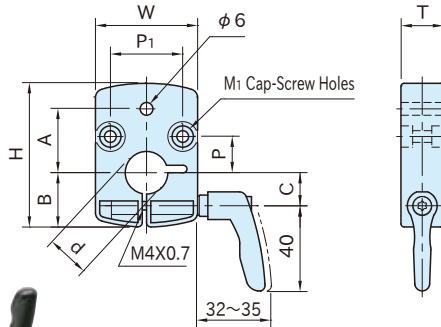

Body	Adjustable Handle
Die-cast zinc(ZDC1) Black	Die-cast zinc(ZDC1) Painted Black

Part Number	d (^{+0.1} / ₀)	W	H	T	M1	P	P1	A	B	C	Weight (g)	Proper Indicators
SKPZN04-08	8	33	47.5	15	M4	23.5	21	22	17	11	100	SDP-04
SKPZN04-10	10										100	
SKPZN04-12	12										100	
SKPZN04-14	14										100	
SKPZN09-12	12	48	67.4	20	M5	17	34	30	25.4	15.5	190	SDP-09-N
SKPZN09-14	14										190	
SKPZN09-16	16										190	
SKPZN09-20	20										190	

Features:

- Plate that allows preventing the spindle from turning due to vibrations from the machine.
- Suitable for positively locking the spindle for a long period of hours
- For details of the adjustable handle (FKF type).

How To Use

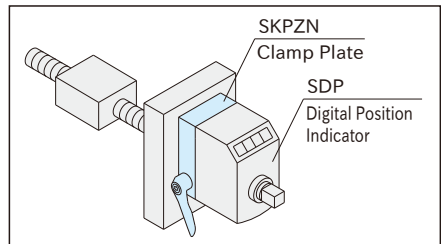

These clamp plates can be used with **SDP-04** or **SDP-09-N** Digital Position Indicators