

# SKP

# CLAMP PLATES

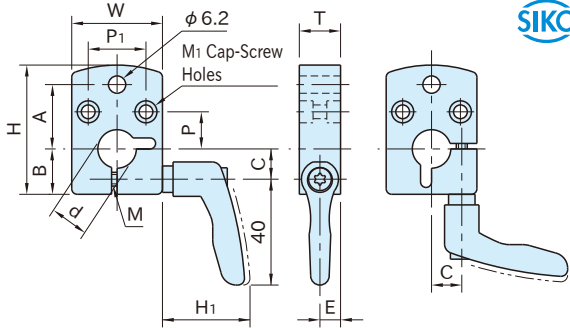

**SKP-04-1 SKP-09-1**  
(Style 1)

**SKP-04-3 SKP-09-3**  
(Style 3)

Body	Adjustable Handle
Aluminum alloy (A6063) Black	Die cast zinc (ZDC1) Coated finish Black

Part Number	d ( $+0.1$ / $-0.05$ )	W	H	T	M <sub>1</sub>	P	P <sub>1</sub>	A	B	H <sub>1</sub>	M	C	E	Weight (g)	Proper Indicators
<b>SKP-04-1</b>	14	33	47	15	M4	23.5	21	22	16.5	32~35	M4×0.7	11	7.5	95	SDP-04
<b>SKP-04-3</b>	Others <a href="#">On Request</a>														
<b>SKP-09-1</b>	20	48	67.5	20	M5	17	34	30	25.5	32~35	M5×0.8	17	10	190	SDP-09-N
<b>SKP-09-3</b>	Others <a href="#">On Request</a>														

### Features

Plate that allows preventing the spindle from turning due to vibrations from the machine.

Ordering Example for  
On Request Clamp Plates

## SKP-04-1 - 10

Part Number of Standard Indicator

Custom Hole Diameter

(Options for SKP-04 : 8, 10, 12 & 15  
(Options for SKP-09 : 8,10,12,14,15,16,18)

### Application Example

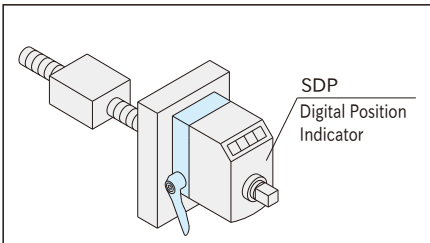

Use with a **SDP-04** or **SDP-09-N** Digital Position Indicator.