

# SKPAR

# CLAMP PLATES (PNEUMATIC)

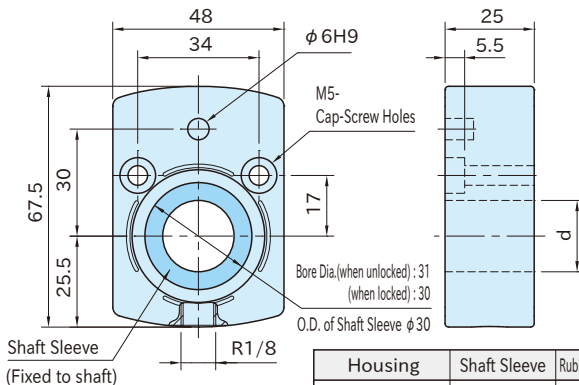

**★One Point**  
Perfect for Remote Operation

Housing	Shaft Sleeve	Rubber Element
Die-cast zinc(ZDC1)	Steel (SUM22L)	EPDM rubber

Part Number	d (H7)	Max. Operating Air Pressure (MPa)	Max. Holding Torque (N·m)	Weight (g)	Proper Indicator
SKPAR09-12	12	0.6	3	328	SDP-09-N
SKPAR09-14	14			318	
SKPAR09-15	15			313	
SKPAR09-16	16			308	
SKPAR09-20	20			288	

### Features:

- Once air pressure is applied, the built-in rubber element expands to lock the shaft sleeve secured to the shaft.
- Multiple Clamp Plates provided with compressed air connection allow clamping and unclamping in one operation.
- These plates prevent the spindle from turning due to vibrations from the machine.

### Caution

- Do not apply air pressure without the shaft inserted through.
- Oil, grease, dust or the like can affect holding power.

### How To Use

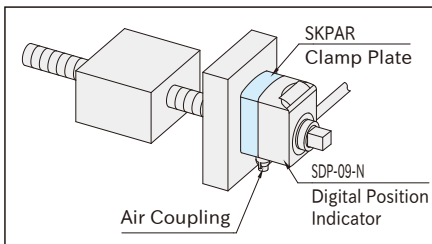

These clamp plates can be used with **SDP-09-N** Digital Position Indicators.

### Technical Information

