

QLRCF

THRUST CLAMPS (Vertical)



Light-Duty
(Marked with Blue Arrow)



Heavy-Duty
(Marked with Black Arrow)

Body/Lever Arm	Cam	Handle
Steel (S45C) Black oxide finish	Steel (SCM415) Carburized-hardened Black oxide finish	Phenolic plastic Black matte

M1-4 Lever-Arm Mounting Holes (angle between 2 holes : 90°)
(4 options of mounting position)

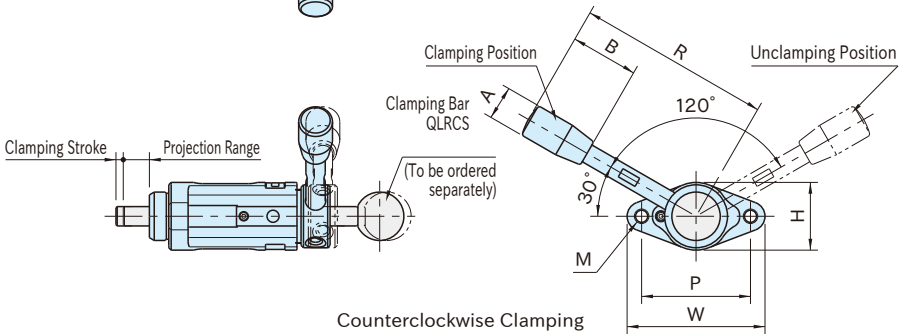
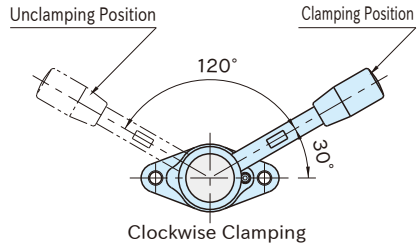
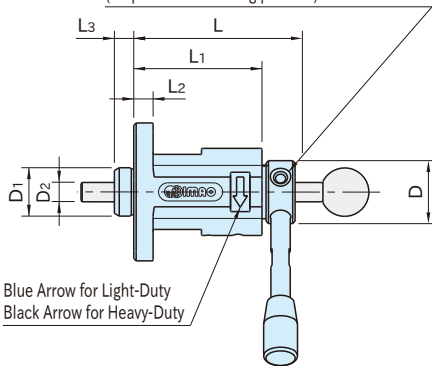

Series	Clamping Stroke	D ₂	W	H	L ₂	M	P	L	L ₁	L ₃	D	D ₁ (^{-0.04} / _{-0.08})	R	B	A	M ₁
QLRCF-08	1.5	8	57	28	8	M 6X1 (Prepared Hole5.2)	45	68.5	53	8	26	20	80	28	14	M5X0.8
QLRCF-12	2.3	12	85	40	12	M10X1.5(Prepared Hole8.5)	65	90.7	72	12	36	30	132	50	21	M6X1