

QLPDH

PULL CLAMPS (Heavy)



★ **Key Point**
Easy clamping without screws.

Note) Clamping Pins or Screws must be ordered separately.

Body & Clamp Ring	Handle Shank	Handle
SCM440 steel Quenched and tempered Black oxide finish	S45C steel Quenched and tempered Black oxide finish	Phenolic plastic Black

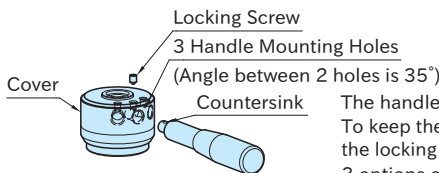
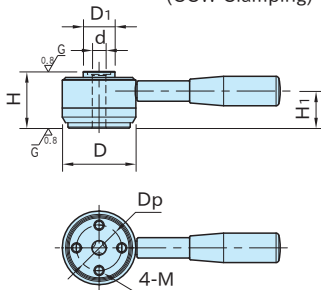
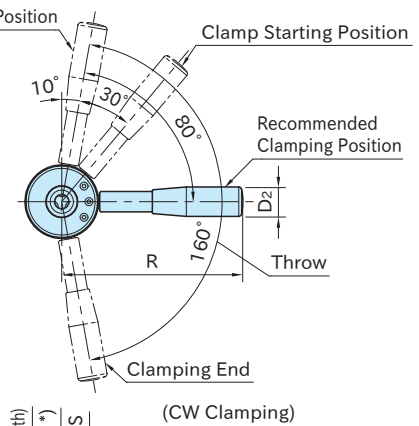
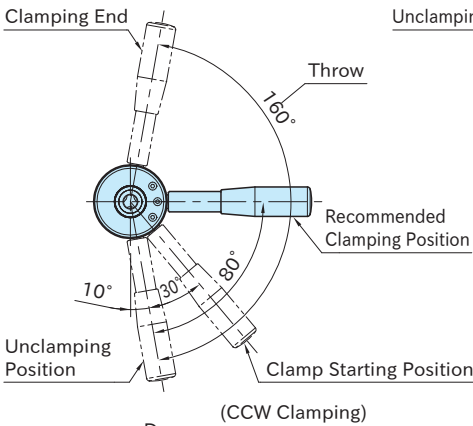

The handle can be removed by loosening the locking screw. To keep the handle mounted permanently, make sure that the locking screw is fully tightened.
3 options of handle mounting position.