

# EFH

# PLASTIC HINGES

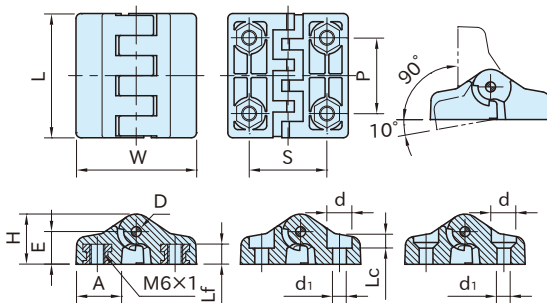

Original ELESA Model CFA/F



Body	Pivot Pin	Insert
Polyamide plastic Black matte	Stainless steel (SUS303)	Brass Nickel plated finish

**EFH-SS**

(Tapped)

**EFH-CH**

(Hex.-Socket-Head-  
Cap-Screw Holes)

**EFH-SH**

(Countersunk-  
Head-Screw Holes)

**EFH-SS** (Tapped)

Part Number	W	L	S	P	H	Lf	E	A	D	Weight (g)
<b>EFH5050SS-90</b>	48	49.5	31	30.2	20	8	13	18	4	42
<b>EFH6565SS-90</b>	63.5	65	40	40	25	9	16	24	5	84

**EFH-CH** (Hex.-Socket-Head-Cap-Screw Holes)

Part Number	W	L	S	P	H	d	d <sub>1</sub>	Lc	E	A	D	Weight (g)
<b>EFH5050CH-90</b>	48	49.5	31	30.2	20	10	5.5	5.5	13	18	4	29
<b>EFH6565CH-90</b>	63.5	65	40	40	25	11	6.5	6.5	16	24	5	62

**EFH-SH** (Countersunk-Head-Screw Holes)

Part Number	W	L	S	P	H	d	d <sub>1</sub>	E	A	D	Weight (g)
<b>EFH5050SH-90</b>	48	49.5	31	30.2	20	10	5.5	13	18	4	29
<b>EFH6565SH-90</b>	63.5	65	40	40	25	12.5	6.5	16	24	5	62

**Note:**

Use in hot or highly humid circumstances can deteriorate the plastic material properties.

**Technical Information**

- Pivot angle : Max. 100°
- Working temperature : Between -20°C and 80°C

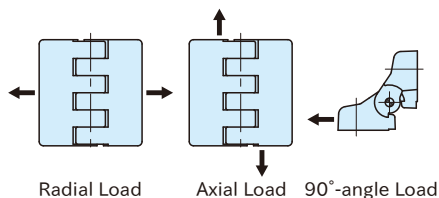

Part Number	Radial Load		Axial Load		90°-angle Load		Max. Screw Torque (N·m)
	Allowable Load E <sub>r</sub> (N)	Breaking Load R <sub>r</sub> (N)	Allowable Load E <sub>a</sub> (N)	Breaking Load R <sub>a</sub> (N)	Allowable Load E <sub>90</sub> (N)	Breaking Load R <sub>90</sub> (N)	
<b>EFH5050SS-90</b>	470	3250	330	3250	110	1540	5
<b>EFH5050CH-90</b>	370	3300	380	3600	320	2490	2
<b>EFH5050SH-90</b>	310	2880	300	2960	320	2490	2
<b>EFH6565SS-90</b>	1550	7780	1150	5780	760	3820	5
<b>EFH6565CH-90</b>	1000	6550	810	5410	720	3980	5
<b>EFH6565SH-90</b>	1010	7010	840	5680	790	3960	3