

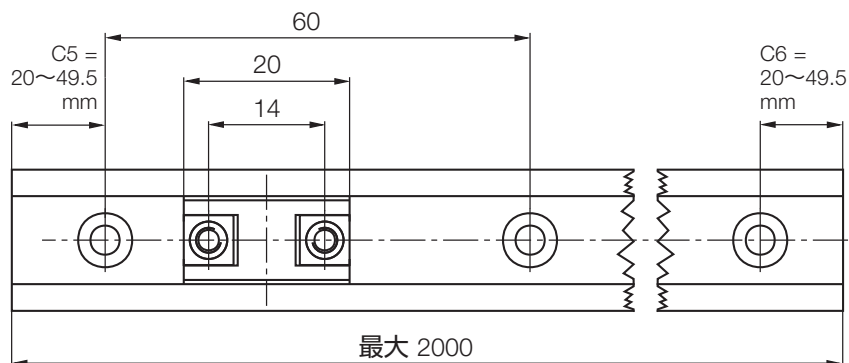

## データ:

製品番号キャリッジ	NW-02-17
製品番号レール	NS-01-17
レール重量	150 g/m
キャリッジ重量	1.7 g
レール最大長さ	1960 mm
標準穴配置対称	(C5=C6)
与圧調整 (最大)	1N



## 許容静荷重と断面2次モーメント

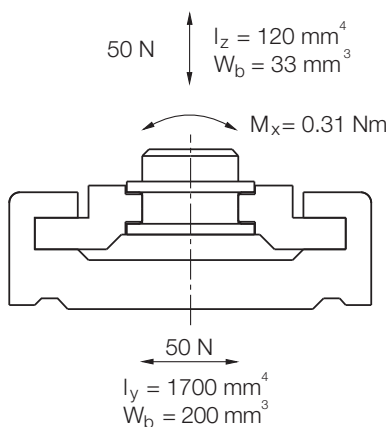
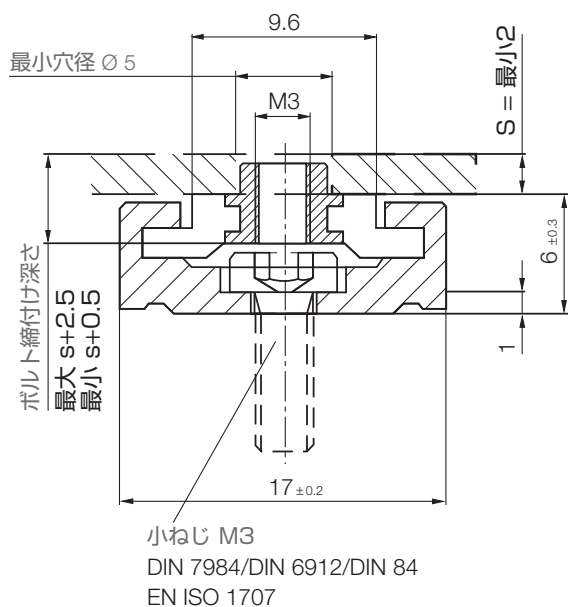

$M_y = 0.18 \text{ Nm}$   
 $M_z = 0.18 \text{ Nm}$

## ドライリンNK 組立品 (キャリッジ+レール)



### 製品番号の構成

