

ドゥーグリップ / ヘリグリップ
突切加工用チップ

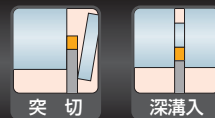

突切工具

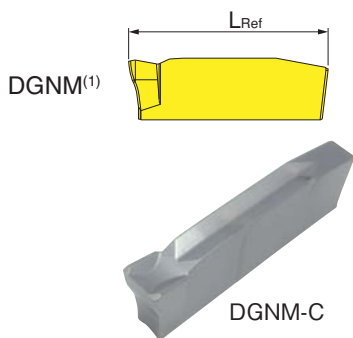

DGNM (ドゥーグリップ)

販売単位：10個

型番	プレーカ	寸法 (mm)				PVDコーティング		
		W	R	L	加工深さ Tmax	IC328	IC354	IC908
DGNM 3202C ⁽¹⁾	C	3.18	0.20	20.0	∞	●	○	●
DGNM 3202J ⁽¹⁾	J	3.18	0.20	20.0	∞	○	○	●

4mm幅以上のチップは、ねじれ刃構造 (1~3mm幅チップはねじれていません)。

(1) 1コーナー使いタイプ

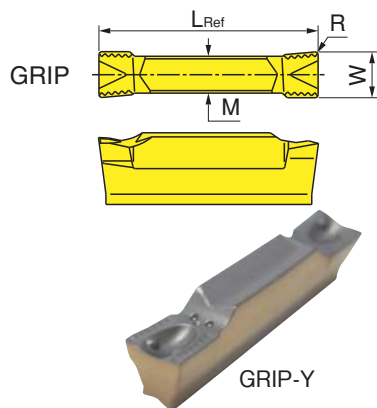

GRIP (ヘリグリップ)

販売単位：10個

型番	寸法 (mm)				PVDコーティング					CVDコーティング <small>超微粒子超硬</small>			
	W±0.05	R±0.05	M	L	IC354	IC807	IC808	IC830	IC908	IC418	IC5010	IC8250	IC08
GRIP 3002Y	3.0	0.2	2.30	16.0	●	●	●	●	●			●	●
GRIP 3003Y	3.0	0.3	2.30	16.0	●		●	●	●	●	●	●	●
GRIP 4002Y	4.0	0.2	2.80	19.0	●	●	●	●	●			●	●
GRIP 4004Y	4.0	0.4	2.85	19.0	●	●	●	●	●	●	●	●	●
GRIP 5005Y	5.0	0.5	3.30	19.0	●	●	●	●	●	●	●	●	●
GRIP 5008Y	5.0	0.8	3.35	19.0	●	●	●	●	●	●	●	●	
GRIP 6005Y	6.0	0.5	4.20	19.0	●	●	●	●	●	●	●	●	
GRIP 6008Y	6.0	0.8	4.20	19.0	●	●	●	●	●	●	●	●	
GRIP 3015Y	3.0	1.5	2.10	16.0		●	●	●	●	●	▲	●	●
GRIP 4020Y	4.0	2.0	2.80	19.0		●	●	●	●	●	▲	●	●
GRIP 5025Y	5.0	2.5	3.40	19.0		●	●	●	●	●	▲	▲	
GRIP 6030Y	6.0	3.0	4.00	19.0		●	●	●	●	●	▲	▲	●

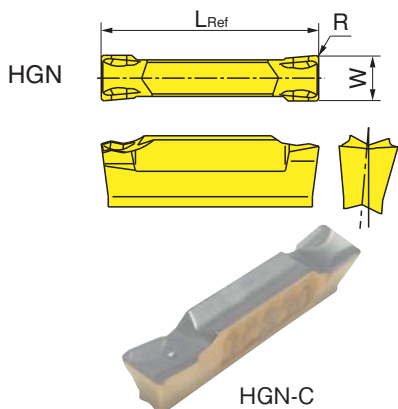

HGN

販売単位：10個

型番	寸法 (mm)			PVDコーティング					サーメット
	W±0.05	R	L	IC308	IC328	IC354	IC830	IC908	IC30N
HGN 3002J	3.0	0.2	16.1		●	●	●		
HGN 3003C	3.0	0.3	15.8	●	●	●	●	●	●
HGN 3003UT	3.0	0.3	15.8		○	○			