

클램프 • DIN 6316 거위목 형
EH 23160.



제품 설명

재질

- 열처리 스틸, 에나멜 코팅

그림

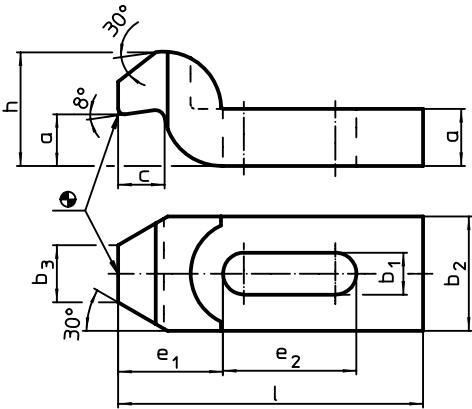

주문 정보

기본 치수 b ₁ [mm]	치수								스크류용		부품번호	
	l	a	b ₂	b ₃	c	e ₁	e ₂	h	[mm]	[인치 (inch)]		[g]
6,6	60	10	20	10	8	20	20	20	M 6	1/4	81	23160.0007
9,0	80	12	25	12	9	25	25	24	M 8	5/16	165	23160.0009
11,0	100	15	30	15	12	32	32	30	M10	3/8	301	23160.0011
14,0	125	20	40	20	16	40	40	40	M12, M14	1/2	679	23160.0014
18,0	125	25	50	25	20	49	40	50	M16, M18	5/8	1059	23160.0018¹⁾
	160	25	50	25	20	49	50	50	M16, M18	5/8	1356	23160.0019
22,0	160	30	60	30	24	55	55	60	M20	3/4	1898	23160.0022¹⁾
	200	30	60	30	24	55	70	60	M20	3/4	2383	23160.0023
26,0	200	35	70	35	28	72	60	70	M24	1	3303	23160.0026¹⁾
	250	35	70	35	28	72	80	70	M24	1	4115	23160.0027
33,0	250	40	80	40	40	91	80	80	M30	1 1/4	4500	23160.0034¹⁾
	315	50	80	40	40	91	100	100	M30	1 1/4	8340	23160.0035

¹⁾ 이 치수들은 DIN 규격이 아님.

적용 예

