

## Wheel hanger for electric operation

Type .R93

Zinc plated steel double wheel hanger with side guide rollers, straight movement, with pendulum hinge and adjustable screw with nut (for electrically operated doors).

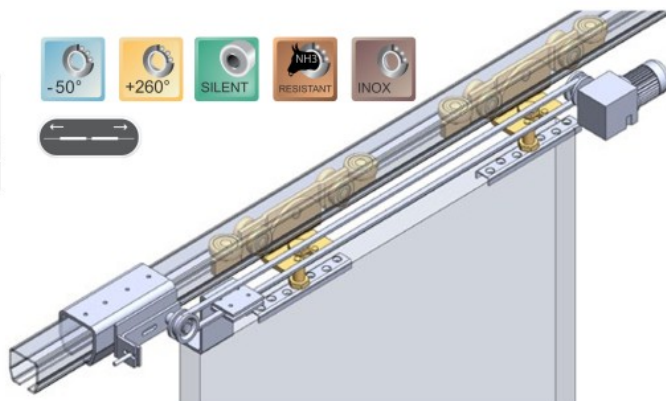
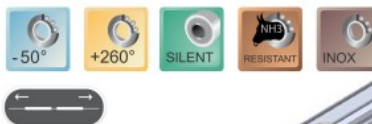
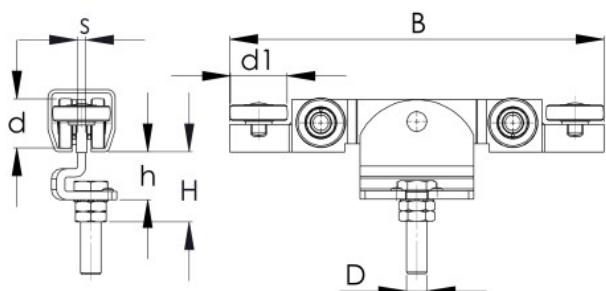

NIKO Profile No.	23.000	24.000	25.000	26.000	27.000
Wheel hanger No.	23.R93	24.R93	25.R93	26.R93	27.R93
Load per wheel hanger (SWL kg)	70	120	240	475	700
Dimension B (mm)	216	280	360	385	480
Dimension H (mm)	45-75	52-85	65-95	95-180	110-200
Dimension D (mm)	M12X60	M16X70	M20X80	M24X150	M30X170
Dimension h (mm)	31	36	46	65	75
Dimension d1 (mm)	34	40	55	68	73
Dimension d (mm)	28	34	48	60	89
Dimension s (mm)	4.5	6	8	10	20

## Weld-on wheel hanger for electric operation

Type .R97

Zinc plated steel double wheel hanger with side guide rollers, straight movement, with pendulum hinge and plain welding plate (for electrically operated doors).

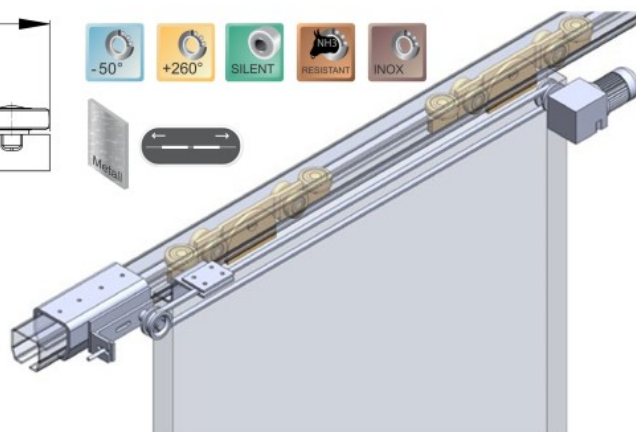
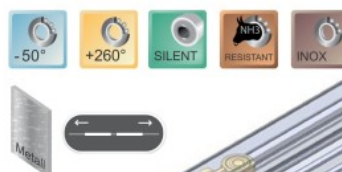
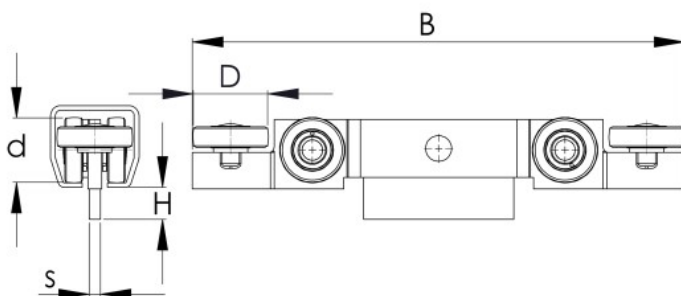

NIKO Profile No.	23.000	24.000	25.000	26.000	27.000
Wheel hanger No.	23.R97	24.R97	25.R97	26.R97	27.R97
Load per wheel hanger (SWL kg)	70	120	240	475	700
Dimension B (mm)	216	280	360	385	480
Dimension H (mm)	14	19	21	22	29
Dimension D (mm)	34	40	55	68	73
Dimension d (mm)	28	34	48	60	89
Dimension s (mm)	4.5	6	8	10	20

### Heavy Duty Sliding Door Fittings

We reserve the right for technical amendments without obligation.  
The product pictures and drawings depicted in this catalogue do not always reflect all available sizes.