

六角穴付きショルダーボルト(ストリッパーボルト) Hexagon Socket Head Shoulder Screws

- 材 料：構造用合金鋼
- 硬 さ：HRC34~44
- 表面処理：黒色酸化被膜
- ね じ：JIS B 0205 (メートル並目ねじ)
ANSI B1.1のUNC
- 等 級：JIS B 0209の6g又は2級
ANSI B1.1の3A

- Material : Special Alloy Steel
- Hardness : HRC34~44
- Surface Treatment : Black Oxide
- Screw Threads : JIS B 0205 (Coarse)
ANSI B1.1, UNC
- Class of Thread : JIS B 0209, 6g
ANSI B1.1, 3A

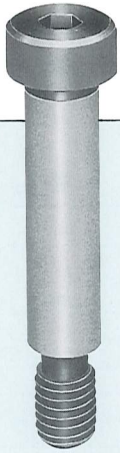

SH型 SH TYPE

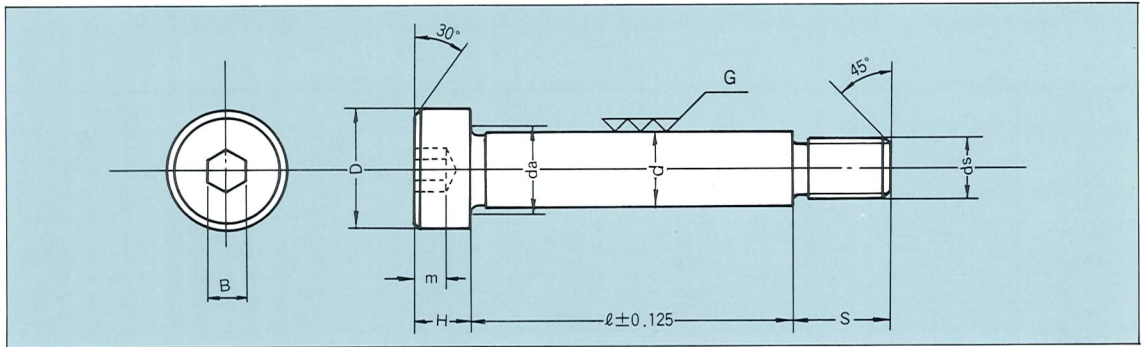

単位mm

呼び Nom Size d	d		D		H		B		m	da	S	ds (ねじの呼び) Screw Thread
	最大 max	最小 min	最大 max	最小 min	最大 max	最小 min	最大 max	最小 min				
6	5.990	5.960	10.00	9.78	4.50	4.32	3.066	3.006	2.4	6.8	9.5	M 5×0.8
8	7.987	7.951	13.00	12.73	5.50	5.32	4.085	4.010	3.3	9.2	11	M 6×1.0
10	9.987	9.951	16.00	15.73	7.00	6.78	5.085	5.010	4.2	11.2	13	M 8×1.25
12	11.984	11.941	18.00	17.73	8.00	7.78	6.085	6.010	4.9	14.2	16	M10×1.5
16	15.984	15.941	24.00	23.67	11.00	10.73	8.103	8.013	6.6	18.2	18	M12×1.75
20	19.980	19.928	30.00	29.67	14.00	13.73	10.103	10.013	8.8	22.4	22	M16×2.0



ST型 ST TYPE

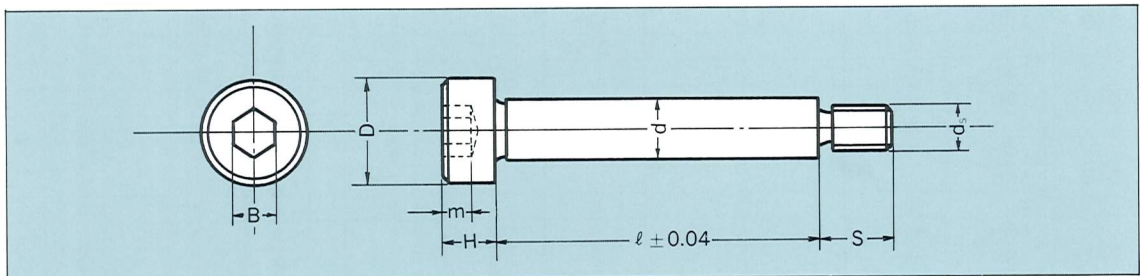

単位mm

呼び Nom Size d	d		D		H		B		m	S	ds (ねじの呼び) Screw Thread
	最大 max	最小 min	最大 max	最小 min	最大 max	最小 min	最大 max	最小 min			
6	6.00	5.95	10.00	9.78	5.00	4.82	4.085	4.010	2.5	9.5	M 5×0.8
8	8.00	7.94	13.00	12.73	6.00	5.82	5.085	5.010	3	11	M 6×1.0
10	10.00	9.94	16.00	15.73	8.00	7.78	6.085	6.010	4	13	M 8×1.25
13	13.00	12.93	18.00	17.73	10.00	9.78	8.103	8.013	5	16	M10×1.5
16	16.00	15.93	24.00	23.67	14.00	13.73	10.103	10.013	7	18	M12×1.75
20	20.00	19.91	30.00	29.67	18.00	17.73	14.196	14.016	9	22	M16×2.0