

ER, RB
 円筒穴(止めねじ付き)、円筒外径面
 d 12 ~ 60 mm

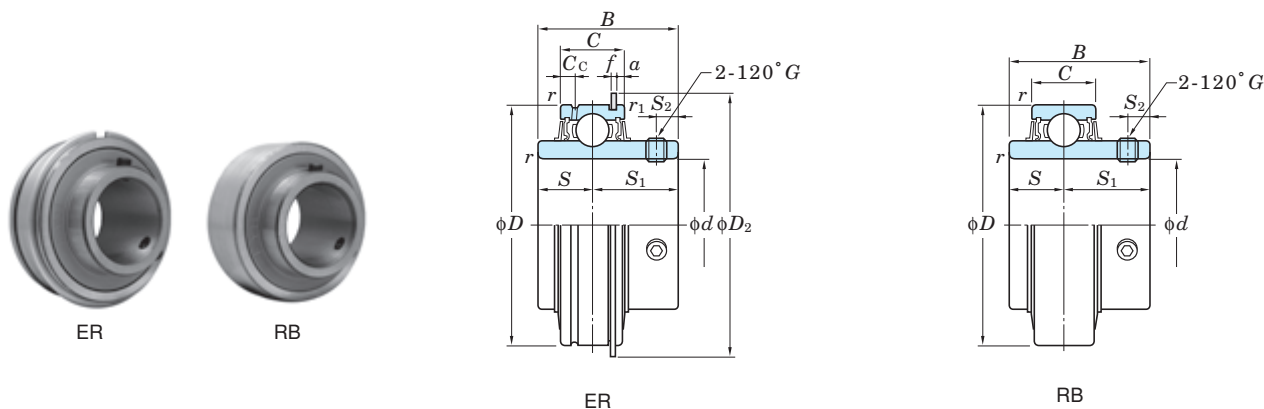

| 軸 径, d | | 主 要 寸 法 (mm) | | | | | 基本定格荷重 (kN) | | 係数 | 軸受呼び番号 | |
|----------|---------|-----------------|------|-----|----------|------------|----------------|----------|-------|----------|----------|
| (mm) | (inch) | D | B | C | r (最小) | r_1 (最小) | C_r | C_{0r} | f_0 | ER | RB |
| 12 | — | 47 | 31 | 16 | 0.6 | 0.5 | 12.8 | 6.65 | 13.2 | ER201 | RB201 |
| | $1/2$ | 47 | 31 | 16 | 0.6 | 0.5 | 12.8 | 6.65 | 13.2 | ER201-8 | RB201-8 |
| 15 | — | 47 | 31 | 16 | 0.6 | 0.5 | 12.8 | 6.65 | 13.2 | ER202 | RB202 |
| | $5/8$ | 47 | 31 | 16 | 0.6 | 0.5 | 12.8 | 6.65 | 13.2 | ER202-10 | RB202-10 |
| 17 | — | 47 | 31 | 16 | 0.6 | 0.5 | 12.8 | 6.65 | 13.2 | ER203 | RB203 |
| 20 | $3/4$ | 47 | 31 | 16 | 1 | 0.5 | 12.8 | 6.65 | 13.2 | ER204-12 | RB204-12 |
| | — | 47 | 31 | 16 | 1 | 0.5 | 12.8 | 6.65 | 13.2 | ER204 | RB204 |
| 25 | $7/8$ | 52 | 34.1 | 19 | 1 | 0.5 | 14.0 | 7.85 | 13.9 | ER205-14 | RB205-14 |
| | — | 52 | 34.1 | 19 | 1 | 0.5 | 14.0 | 7.85 | 13.9 | ER205 | RB205 |
| | 1 | 52 | 34.1 | 19 | 1 | 0.5 | 14.0 | 7.85 | 13.9 | ER205-16 | RB205-16 |
| 30 | $1 1/8$ | 62 | 38.1 | 22 | 1 | 0.5 | 19.5 | 11.3 | 13.9 | ER206-18 | RB206-18 |
| | — | 62 | 38.1 | 22 | 1 | 0.5 | 19.5 | 11.3 | 13.9 | ER206 | RB206 |
| 35 | $1 1/4$ | 72 | 42.9 | 24 | 1.1 | 0.5 | 25.7 | 15.4 | 13.9 | ER207-20 | RB207-20 |
| | $1 3/8$ | 72 | 42.9 | 24 | 1.1 | 0.5 | 25.7 | 15.4 | 13.9 | ER207-22 | RB207-22 |
| | — | 72 | 42.9 | 24 | 1.1 | 0.5 | 25.7 | 15.4 | 13.9 | ER207 | RB207 |
| 40 | $1 1/2$ | 80 | 49.2 | 28 | 1.1 | 0.5 | 29.1 | 17.8 | 14.0 | ER208-24 | RB208-24 |
| | — | 80 | 49.2 | 28 | 1.1 | 0.5 | 29.1 | 17.8 | 14.0 | ER208 | RB208 |
| 45 | $1 5/8$ | 85 | 49.2 | 28 | 1.1 | 0.5 | 34.1 | 21.3 | 14.0 | ER209-26 | — |
| | $1 3/4$ | 85 | 49.2 | 28 | 1.1 | 0.5 | 34.1 | 21.3 | 14.0 | ER209-28 | — |
| | — | 85 | 49.2 | 28 | 1.1 | 0.5 | 34.1 | 21.3 | 14.0 | ER209 | — |
| 50 | $1 7/8$ | 90 | 51.6 | 28 | 1.1 | 0.5 | 35.1 | 23.3 | 14.4 | ER210-30 | — |
| | — | 90 | 51.6 | 28 | 1.1 | 0.5 | 35.1 | 23.3 | 14.4 | ER210 | — |
| 55 | 2 | 100 | 55.6 | 30 | 1.5 | 0.5 | 43.4 | 29.4 | 14.4 | ER211-32 | — |
| | $2 1/8$ | 100 | 55.6 | 30 | 1.5 | 0.5 | 43.4 | 29.4 | 14.4 | ER211-34 | — |
| | — | 100 | 55.6 | 30 | 1.5 | 0.5 | 43.4 | 29.4 | 14.4 | ER211 | — |
| 60 | $2 1/4$ | 110 | 65.1 | 32 | 1.5 | 0.5 | 52.4 | 36.2 | 14.4 | ER212-36 | — |
| | — | 110 | 65.1 | 32 | 1.5 | 0.5 | 52.4 | 36.2 | 14.4 | ER212 | — |
| | $2 3/8$ | 110 | 65.1 | 32 | 1.5 | 0.5 | 52.4 | 36.2 | 14.4 | ER212-38 | — |