

Max. 30mm Blade Length!

- 30mm blade length and originally designed breaker ensured maximum 30mm Chamfering process without chattering
- Line-up 5°~85° Angle process are ensured

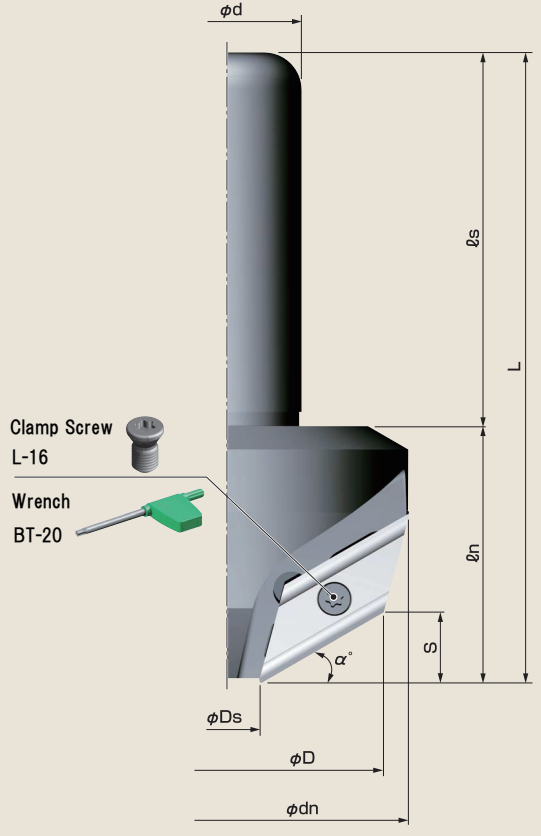

Corner Chamfering

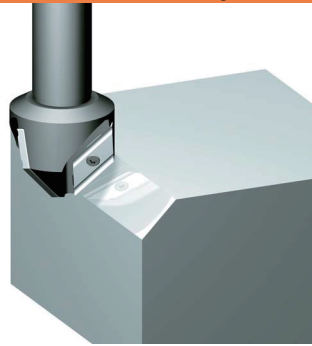

Body

Model. No.	Blades	Dimensions (mm)								α°
		φD	φDs	φd	φdn	L	ℓs	ℓn	S	
NK4554X-1	1	54.9	12.0	32		135	80	55	21.4	45
NEW NK0574X	3	74.8	15.0	32	102.8	135	80	55	2.6	5
NEW NK1074X	3	74.5	15.0	32	99.5	135	80	55	5.2	10
NK1571X	3	73.3	15.0	32	95.2	135	80	55	7.8	15
NK2070X	3	71.8	15.0	32	90.3	135	80	55	10.3	20
NK2568X	3	69.8	15.0	32	84.9	135	80	55	12.8	25
NK3080X	3	67.4	15.0	32	79.0	135	80	55	15.1	30
NK3563X	3	64.6	15.0	32	72.8	135	80	55	17.4	35
NK4060X	3	61.4	15.0	32	66.3	135	80	55	19.5	40
NK4557X	3	57.9	15.0	32		135	80	55	21.4	45
NK5056X	3	57.0	18.0	32		135	80	55	23.2	50
NK5556X	3	56.8	22.0	32		135	80	55	24.8	55
NK6054X	3	54.3	24.0	32		135	80	55	26.3	60
NK6553X	3	53.6	28.0	32		145	80	65	27.5	65
NK7052X	3	52.8	32.0	32		145	80	65	28.5	70
NK7550X	3	50.7	35.0	32		145	80	65	29.3	75
NEW NK8048X	3	48.5	38.0	32		145	80	65	29.9	80
NEW NK8547X	3	47.3	42.0	32		145	80	65	30.3	85

※ Inset is not equipped as standard accessory

※ Clamp screw and wrench are supplied as standard accessory

Processing Example

[C20 Chamfering]

- Body : NK4557X
- Inset : X63GUR NK6060

- Material : SUS304
- Rotation Speed : 800r.p.m
- Table feed : 150mm/min
- Cutting Depth : C20
- Cutting Oil : None



Result

Good!
By one pass process, C20 Chamfer has been successfully made without chattering

Cutting Conditions

X63GUR					
Material	material Model	NK1010	NK2020	NK6060	AC15N
	Feed per blade (fz)	Rotation speed (r.p.m.)			
General Steel	0.05~0.15		1,000~2,000	1,000~2,000	1,000~2,000
Alloy Steel	0.05~0.15		1,000~2,000	1,000~2,000	1,000~2,000
Stainless Steel	0.05~0.15		700~1,500	700~1,500	700~1,500
Aluminum, Resin, Brass	0.08~0.2	3,000~5,000			
Cast Steel	0.05~0.15	1,000~2,000			

● According to the shape of work, clamp condition and large or small chamfering amount, the cutting condition will have to be adjusted.

● Yellow marked condition is recommended for the material listed

● In case of chamfering process of Stainless steel, kindly take down cutting

Insert

Figure	Model.No.	Material	Blade Shape	Coating	Usable corner	Quantity per box
	X63GUR NK1010	Carbide K10	Sharp edge	None	2	3
	X63GUR NK2020	Carbide M20	Honing edge	None	2	3
	X63GUR NK6060	Carbide M20	Honing edge	TiAlN	2	3
	X63GUR AC15N	Fine particles Carbide	Honing edge	AlCrN	2	3