



HN-1-

- SIZE**
- 1 35mm
 - 2 50mm
 - 3 60mm
 - 4 80mm



재질

아연합금

표면처리

크롬도금

중량

- HN-1-1 : 11g
- HN-1-2 : 32g
- HN-1-3 : 50g
- HN-1-4 : 92g

특징

좌우검용, 탈부착이 용이

용도

환경 시험기기, 공작기계, 각종 산업기기

Material

Zinc alloy die-cast

Finish

Bright chrome plated

Weight

- HN-1-1 : 11g
- HN-1-2 : 32g
- HN-1-3 : 50g
- HN-1-4 : 92g

Feature

For both left and right use
Easy to attach and detach

Specific use

Various industrial equipment etc.

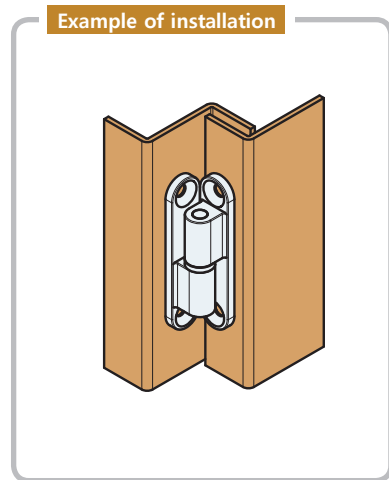
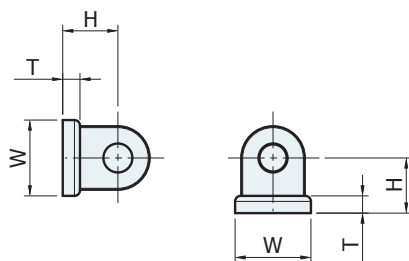
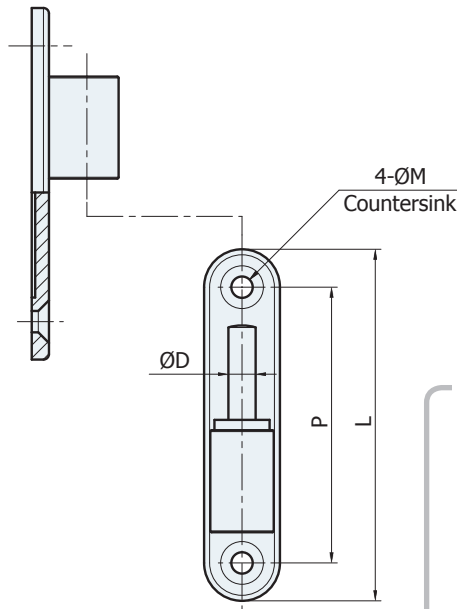

	L	P	W	H	T	D	M
HN-1-1	35	27	8	6	2	3	3.1
HN-1-2	50	40	11	8	2.5	4	3.1
HN-1-3	60	48	13	9.5	3.1	5	4.5
HN-1-4	80	68	14.5	11.5	4	6	4.2